

CLA

Compact sound attenuator for circular ducts

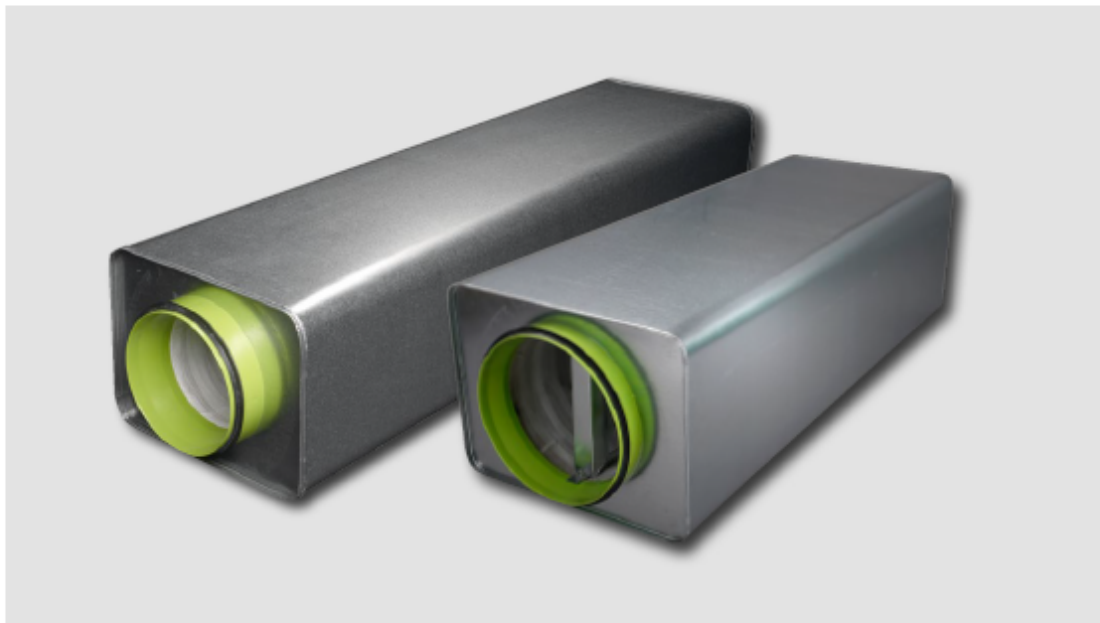

QUICK FACTS

- Extremely low installation height.
- Excellent sound attenuation
- Mineral wool covered with special polyester woven fabric.
- Tightness Class D
- Low pressure drop
- Type-approved to Fire-resistance Classes EI30
- Included in the MagiCAD database

Swegon

Technical Description

General

A rectangular sound attenuator with circular connection spigots. Unique properties regarding installation height, fire-resistance class, fibre-migration proof design and sound attenuation. Patent-pending self-supporting fibre-migration proof surface lining and end wall solution.

Function

When we developed the new CLA, we based the design on what we consider to be the three most important characteristics of a sound attenuator. First and foremost, we wanted to create a product that occupies as little space as possible. If the occupants are to perceive a space as being light and airy despite limited ceiling height, then it is desirable to arrange the suspended ceiling as high as possible and this makes ventilation products with minimal installation height supremely interesting. Small installation dimensions also markedly increase the scope for installation and make the installation work much easier.

The other aspect was the fitters. Building construction workers and fitters complain much too often about sharp corners and sharp edges on the products they handle. We understand exactly what they mean and promised ourselves that we would change this and make their workday both simpler and safer. The third and perhaps the most important requirement we set up when we began developing this product was that low installation height and installation-friendliness absolutely must not impair the sound attenuating properties of the new CLA, preferably the other way around.

Patent-pending Solution

The result of this development work became a sound absorber with the smallest installation height of any similar product available on the market, rounded and grip-friendly corners and edges as well as improved acoustic data compared with the previous CLA variant of our popular sound attenuators.

The key to this success is a completely new, patent-pending fabrication technique.

The unique solution consisting of end walls directly integrated into the connection spigot and our new fibre-migration-proof lining material, where mineral wool is covered with special polyester woven fabric inside the sound attenuator. This provides excellent air tightness. A further feature of the solution is that our new CLA does not have any perforated sheet-metal between the insulation material and the passage through which air flows through the sound attenuator. In traditional solutions, pockets often form by the perforations where dirt can collect, a problem which we've been able to completely eliminate thanks to the self-supporting fibre-migration proof surface lining.

Design

The CLA is made as standard of galvanised sheet steel to Environment Class C2 (corresponds to M2 according to Swedish VVS-AMA 98 Standard).

Naturally the CLA is fibre-migration-proof thanks to our new patent-pending solution with a self-supporting surface layer, which is approved with regard to cleaning, fibre migration, resistance to ageing, emissions, etc. (see TG 0207).

Accessories

No accessories are available for this product.

Pressure drop

The net area is less than the connection diameter to provide improved sound attenuation data (especially in the low frequencies). The pressure drop that CLA duct-to-duct installation generates is specified in Diagrams 1 and 2.

The specified data is based on a uniform air stream in and out of the product. Any dampers, duct bends or other products in the ducting near the sound attenuator will increase its pressure drop and level of flow-generated sound, and will affect its sound attenuating properties.

Installation

The connection spigots on this product are designed for connection to ducts only.

It is important to drive screws or blind rivets into the sheet-metal edge on the connection spigot. See Figure.

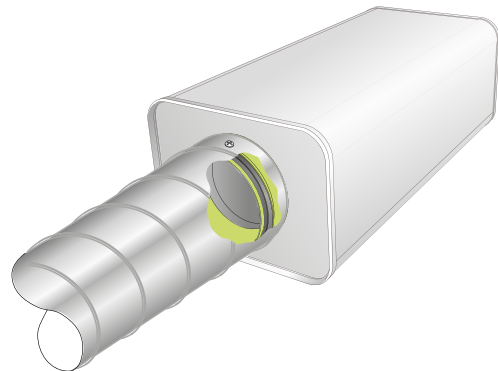

Figure 1. Sheet-metal edge firmly fixed in the connection spigot. For extra reliability, the joint duct should be fastened in the curled up sheet-metal edge (at least 25 mm) inside the connection spigot.

The product should be fixed by means of approved hangers that conform to provisions for load-bearing capacity **R** corresponding to the fire resistance of the building, for example **R 60** for elements of structure to Fire-resistance Class **EI60**.

Maintenance

The product is maintenance-free under normal operating conditions.

In line with its type approval rating, the sound attenuator can be cleaned using a rotating plastic brush.

The normal temperature for (continuous) use is between -30° and +50° C.

Environmental Considerations

The relevant building product declaration is available from our website.

Fire-resistance Class

In applications in which the sound attenuator is to replace a ventilation duct insulated to a specific fire-resistance rating, the CLA can be used provided that the required safety distance is complied with.

Protection against the spread of fire between fire compartments

The long sides of the sound attenuator comply with Fire-resistance Class EI30/E 60 and its ends comply with Fire-resistance Class E60, therefore the isolating capability and integrity of its long sides is maintained for 30 min. and the integrity of the entire sound attenuator is maintained for 60 min.

Ventilation ducts must be run and designed so that in the event of a fire they will not cause ignition in nearby elements of structure and permanent fittings outside the fire compartment in which they are situated, during the period stated in the fire compartment provision. Note that the sound attenuator **cannot** be installed going through structural element that serves as a fire wall. Air treatment system installations that run through an element of structure separating fire compartments must be designed so that the fire-separating capability of the element will be maintained. **BBR 5:6521**.

According to **BBR 5:6213** Fire-resistance Class **EI** must be changed to Class **E**, if the distance to an escape route and to combustible material is sufficient so that it will not impair evacuation safety or increase the risk of fire spread. For ventilation ducts, this means that an appropriate safety distance can be provided instead of insulating with I-rated duct insulation. Safety distance means the shortest distance required so that heat radiation from a hot surface will not ignite combustible material or will not injure persons evacuating the building.

Generally, no safety distance is required for temperatures below 375° C.

The required safety distance specified in our catalogue has thus been calculated for the parallel case (combustible material or persons parallel to the sound attenuator) since it is this case that develops the most incident radiation.

Installation of sound attenuators in ducts to specific fire resistance class arranged at a safe distance to combustible material.

The fire-resistance class requirement of the sound attenuator is governed by the requirements that are applicable to the ventilation duct in which the sound attenuator is installed. The safety distance should be measured at right angles from the surfaces of the sound attenuator. The specified safety distance is based on a critical radiation level for ignition of 10 kW/m² (without pilot flame).

Installation of sound attenuators in ducts to specific fire resistance class with safety distance to persons evacuating a building

This refers to escape routes such as separate stairways in a building or separate corridors within a hotel floor level. Besides the sound attenuator's surface temperature and emissivity, the exposure time that evacuating persons have to endure governs the need for a safety distance and the length of this gap to evacuating persons. The Swedish Board of Housing, Building and Planning Regulation for New Building no. BBR 5:6213, advises: "the distance to evacuating persons should be so far that the radiation level will not exceed 3 kW/m². Higher radiation levels may be acceptable if the time aspects for evacuation and combustion are observed". The 3 kW/m² limit is based on the limit value for unendurable pain during a long period of exposure.

The safety distance shall be measured at right angles from the surfaces of the sound attenuator. The specified safety distance is based on a critical radiation level of 3 kW/m² and an emissivity of 1. Emissivity 1 has been chosen with regard to surface finish such as a painted finish or aging. The end panels are not taken into account since a sound attenuator is normally installed so that the parallel case cannot arise.

CLA-A Mineral wool covered with special polyester woven fabric.

The CLA-A has been granted type approval (TG 0207) for Fire-resistance Classes EI30/E60 and EI60 on condition that the tabulated safety distance to flammable material and/or persons in an escape route, specified in the table on the next page, is complied with.

In the cases in which the safety distance to flammable material and/or persons in an escape route is not complied with, the CLA-A then has Fire-resistance Class EI30/E60.

CLA-B (with mineral wool and surface covering, IS-OVER Cleantec® PLUS)

The CLA-B conforms to Fire-resistance Class E60.

Sizing

Sound attenuation

Sound attenuation is specified to ISO 7235, i.e. static integral attenuation for duct products. The sound pressure level in rooms or outdoors can be calculated manually or by means of Swegon's ProAc Acoustic calculation software. ProAc enables you to make a complete acoustic calculation from the air handling unit to rooms and also plan individual products. ProAc provides full documentation. ProAc can be downloaded from our website on the Internet.

Pressure drop

The net area is less than the connection diameter to provide improved sound attenuation data (especially in the low frequencies). The pressure drop that CLA duct-to-duct installation generates is specified in Diagrams 1 and 2.

The specified data is based on a uniform air stream in and out of the product. Any dampers, duct bends or other products in the ducting near the sound attenuator will increase its pressure drop and level of flow-generated sound, and will affect its sound attenuating properties.

Diagram 1. Pressure drop – Airflow, CLA-A

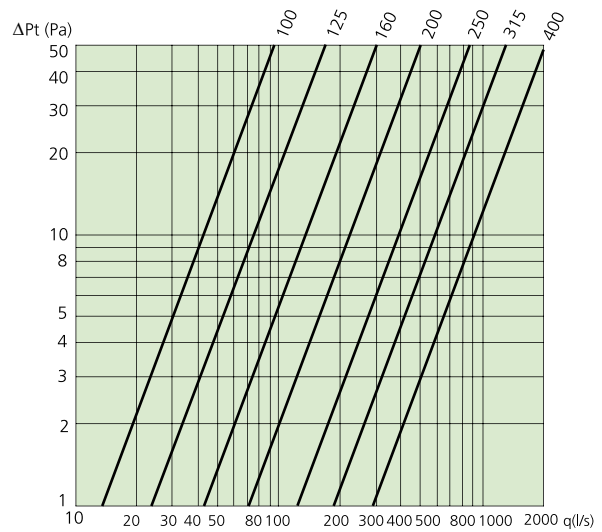
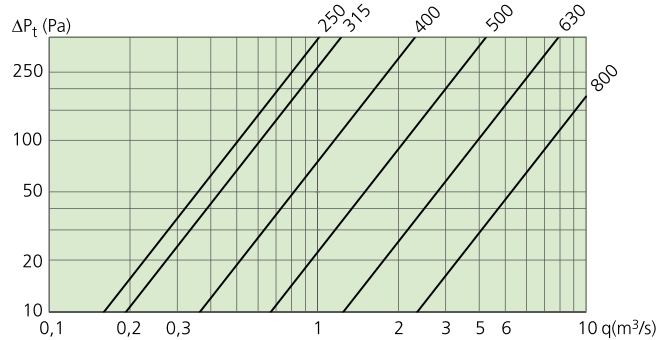

Diagram 2. Pressure drop – Airflow, CLA-B



CLA-A

Design

The new CLA is an industrially fabricated product designed for excellent sound attenuation and ease of installation. There are two different patent applications: one relating to the end wall and the other relating to our new fibre-migration-proof lining, inside the sound attenuator.

The standard CLA is made of galvanised sheet steel.

The connection spigots are fitted with rubber seal rings. Type-approved to Tightness Class D

The fire-resistance class is met by providing adequate safety distance.

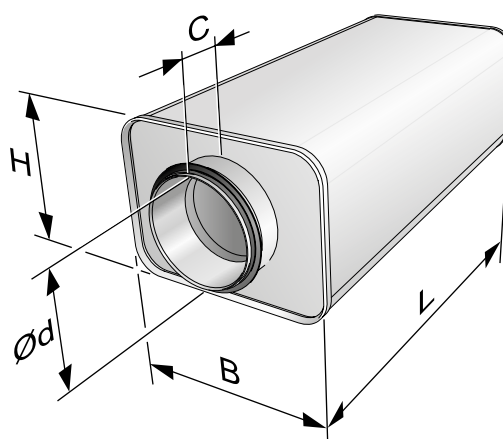

Figure 2. CLA-A – Dimension print

The CLA-A has been granted type approval (TG 0207) for Fire-resistance Classes EI30/E60 and EI60/E60 respectively on condition that the safety distance is complied with.

In the cases in which the safety distance to flammable material and/or persons in an escape route is not complied with, the CLA-A then has Fire-resistance Class EI30/E60.

Pressure drop

The pressure drop that CLA duct-to-duct installation generates is specified in Diagram 1.

Table, CLA-A

Size	B mm	C mm	Ød mm	H mm	Length	
					mm	mm
100	208	45	99	152	500	1000
125	236	45	124	177	500	1000
160	274	45	159	212	500	1000
200	321	45	199	252	500	1000
250	394	45	249	302	500	1000
315	462	45	314	367	500	1000
400	553	60	399	458	500	1000

Sound attenuation, CLA-A

Size	Length (mm)	Ød (mm)	H (mm)	Static integral attenuation, dB to ISO 7235								Weight (kg)	Safety distance in mm	
				63	125	250	500	1K	2K	4K	8K		EI30	EI60
100	500	99	152	7	9	14	26	34	42	35	26	3.2	-	50
	1000	99	152	7	17	26	44	50	50	50	39	6.0	-	50
125	500	124	177	5	9	13	21	29	35	31	20	3.9	-	50
	1000	124	177	7	16	23	39	50	50	47	35	7.2	-	50
160	500	159	212	5	8	13	17	23	31	21	17	5.0	-	50
	1000	159	212	7	13	22	32	45	50	38	25	9.2	-	50
200	500	199	252	5	8	11	15	20	22	14	14	6.3	-	50
	1000	199	252	7	13	20	28	40	45	27	20	11.7	-	50
250	500	249	302	5	6	8	11	15	16	10	7	8.5	-	50
	1000	249	302	6	11	15	20	28	31	18	14	15.7	-	50
315	500	314	367	4	6	7	9	12	8	8	5	11.0	-	50
	1000	314	367	6	10	12	17	24	21	12	7	20.2	-	50
400	500	399	458	4	6	7	9	12	8	6	4	15.1	-	50
	1000	399	458	5	9	12	16	23	14	8	6	27.5	-	50

CLA-B

Design

The CLA-B is a rectangular sound attenuator for connection to circular ducts, is equipped with an acoustic centre baffle for improved sound attenuation data.

The installation height is as much as 80 mm lower than equivalent conventional sound attenuators.

The CLA-B is an excellent option, for kitchen flues for instance (held by means of a fixing clamp for simple removal for cleaning. The sound attenuator is also available in versions without baffle and with smaller duct connection sizes. For further particulars, get in touch with your nearest Swegon representative.

The sound-attenuating material on dimension 500-800, ISOVER Cleantec® PLUS is a type-approved insulation material consisting of long-fibred compressed mineral wool. The mineral wool is covered with a micro-perforated aluminium foil.

ISOVER Cleantec® PLUS is type-approved for cleaning using liquids with a plastic brush or even a high-pressure cleaning apparatus. Naturally it also conforms to relevant standards regarding cleaning, fibre entrainment, resistance to ageing and emissions, etc. to type-approval number 2706/92.

The connection spigots are fitted with rubber seal rings. The standard CLA-B is made of galvanised sheet steel. The CLA-B conforms to Fire-resistance Class E60.

Pressure drop

The pressure drop that CLA-B duct-to-duct installation generates is specified in Diagram 2.

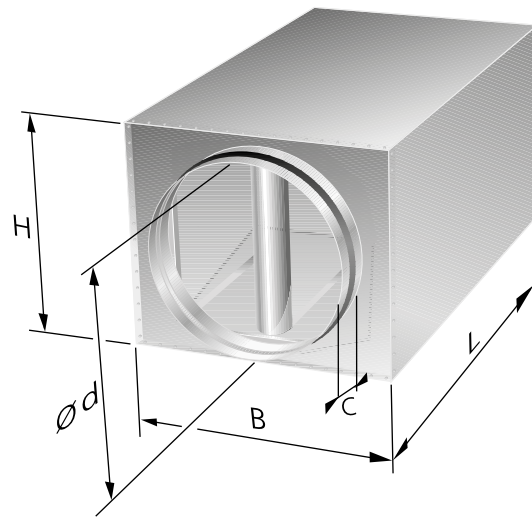

Figure 3. CLA-B – Dimension print

Table, CLA-B

Size	B mm	C mm	Ød mm	H mm	Length	
					mm	mm
250	394	45	249	302	500	1000
315	462	43	314	367	500	1000
400	553	43	399	458	500	1000
500	680	60	499	580	600	1200
630	810	60	629	710	600	1200
800	980	60	799	880	600	1200

Sound attenuation, CLA-B

Size	Length (mm)	Ød (mm)	H (mm)	Static integral attenuation, dB to ISO 7235								Weight (kg)
				63	125	250	500	1K	2K	4K	8K	
250*	500	249	302	5	6	8	14	24	32	20	9	8,4
	1000	249	302	7	12	17	30	43	40	34	16	15,4
315*	500	314	367	4	6	8	14	25	19	14	8	10,7
	1000	314	367	6	10	14	26	45	42	21	12	19,9
400*	500	399	458	4	6	8	14	22	16	10	6	14,4
	1000	399	458	5	9	14	23	40	24	13	9	26,5
500	600	499	580	4	5	15	23	29	20	15	14	24,0
	1200	499	580	5	7	16	24	30	22	16	14	41,0
630	600	629	710	3	4	12	19	22	17	12	9	30,5
	1200	629	710	4	6	13	20	23	18	12	10	50,0
800	600	799	880	2	2	10	12	11	7	6	2	39,5
	1200	799	880	3	4	11	13	11	8	7	3	64,0

*= version similar to CLA-A + centre baffle

Ordering Key

Product

Rectangular sound attenuator with circular connection spigots

CLA-A	aaa-	bbbb
Connection dimensions 100, 125, 160, 200, 250, 315, 400		
Length: 500, 1000		

CLA-B	aaa-	bbbb
Connection dimensions 250, 315, 400, 500, 630, 800		
Length: For connection dimensions 250, 315, 400: 500, 1000 For connection dimensions 500, 630, 800: 600, 1200		

Accessories

No accessories are available for this product.

Specification Text

Example of a specification text conforming to VVS AMA Standard.

Example 1

Swegon type CLA-A compact sound attenuators for connection to circular ducts, with the following functions:

- Self-supporting surface layer
- Fire-resistance Class EI30 without safety distance
- Fire-resistance Class EI60 with 50 mm safety distance

Designation:	CLA-A 160-1000	xx items
--------------	----------------	----------

Example 2

Swegon type CLA-B compact sound attenuators for connection to circular ducts, with the following functions:

- ISOVER Cleantec® PLUS), cleanable using liquids
- Equipped with centre sound baffle

Designation:	CLA-B 630-1200	xx items
--------------	----------------	----------