

SORDO

Sound attenuator for circular ducts

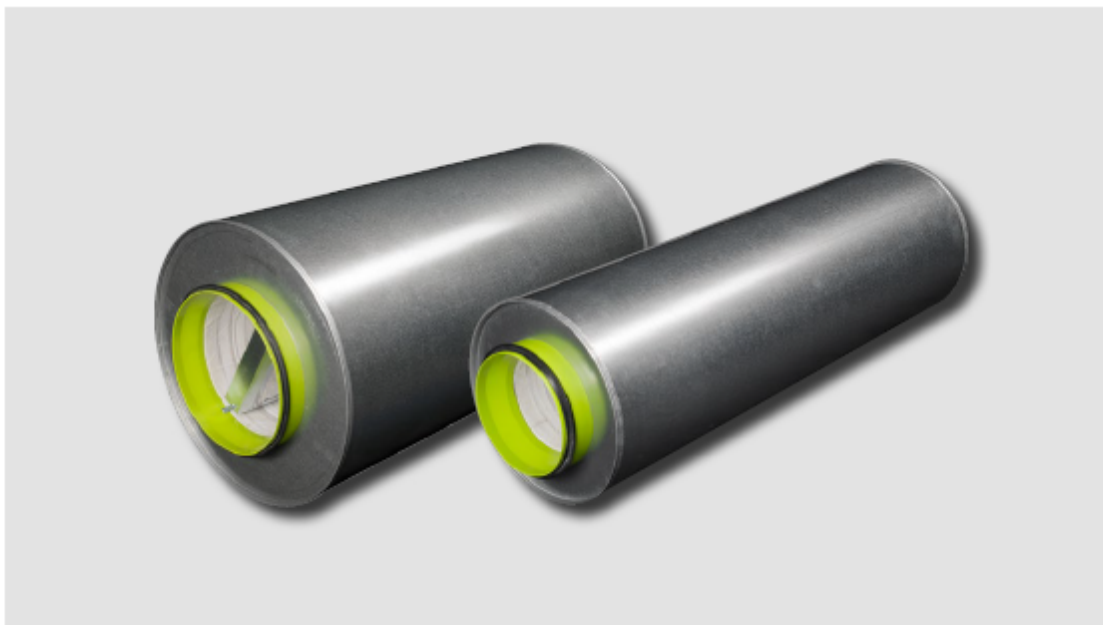

QUICK FACTS

- Mineral wool covered with special polyester woven fabric.
- 100 mm shorter
- Tightness Class D
- Excellent sound attenuation
- Type-approved to Fire-resistance Classes EI30 and EI60
- Included in the MagiCAD database

Swegon

Contents

Technical Description	3
General.....	3
Function	3
Fire-resistance Class	4
Sizing	5
SORDO-A	6
SORDO-C	7
SORDO-B.....	8
SORDO-P.....	9
SORDO-PF	10
Ordering Key	11
Specification Text	11

Technical Description

General

A circular sound attenuator with circular connection spigots.

Unique properties regarding fire-resistance class, fibre-migration proof design and sound attenuation.

Patent-pending self-supporting fibre-migration proof surface lining and end wall solution.

Function

Producers in every line of trade are constantly in pursuit of ways to downsize their products yet retain the same performance. This is also the case in the indoor climate system field. The smaller the products we at Swegon are able to fabricate; the more installation options the subcontractor will have at his disposal. Reduced sizes also make the products easier to handle and install.

It was with these prerequisites in mind that we began to develop the new SORDO, our popular round sound attenuator with circular connection spigots.

Patent-pending Solution

The result of our research work has been the development of a sound attenuator that is 100 mm shorter than our previous SORDO yet with the same excellent acoustical properties as before. Like for the SORDO's rectangular sister sound attenuator the CLA, the success of this design is to a great extent due to a completely new, patent-pending production technique. The unique solution with the end walls integrated directly into the connection spigots and our new self-supporting fibre-migration-proof lining, where mineral wool is covered with a special polyester woven fabric inside the sound attenuator. This solution offers excellent tightness that contributes to the high performance. We have also been able to reduce both the inner and outer diameters of the new SORDO, which is also a reason for its excellent sound attenuation.

Design

The standard SORDO is made of galvanised sheet steel to Environmental Class C2 (equivalent to M2 to VVS-AMA 98).

The SORDO is fibre-migration-proof thanks to our new patent-pending solution with self-supporting surface layer, which is approved with regard to cleaning, fibre migration, resistance to ageing, emissions, etc. (see TG 0783).

Accessory

The SORDO T1 counterflange is a robust flange made of flat steel that has then been galvanised. The dimensions are adapted to DIN 24 154 Parts 2 and 5 German Standard. The counterflange can be fitted on both spiral-fold and longitudinal-fold ducts. Oval bolt holes facilitate installation.

Installation

The connection spigots on this product are designed for connection to ducts only. It is important to drive screws or blind rivets into the sheet-metal edge on the connection spigot. See Figure.

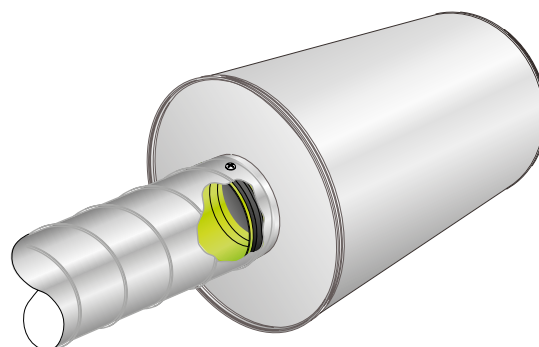

Figure 1. Sheet-metal edge firmly fixed in the connection spigot. For extra reliability, the joint duct should be fastened in the curled up sheet-metal edge (at least 25 mm) inside the connection spigot.

The product can be mounted by means of approved hangers that satisfy the provisions to load bearing capacity rating **R** corresponding to the fire resistance the structural element of the building, for example load bearing capacity rating **R 60** for elements of structure to fire-resistance class **E160**.

Maintenance

The product is maintenance-free under normal operating conditions. According to its type approval rating, the sound attenuator can be cleaned using a rotating plastic brush.

The normal temperature for (continuous) use is between -30° and +50°C.

Environmental Considerations

The relevant building product declaration is available from our website.

Fire-resistance Class

In applications in which the sound attenuator is to replace a ventilation duct insulated to a specific fire-resistance rating, the SORDO can be used provided that the required safety distance is complied with.

Protection against the spread of fire between fire compartments

The long sides of the sound attenuator comply with Fire-resistance Class EI30/E 60 and its ends comply with Fire-resistance Class E60, therefore the isolating capability and integrity of its long sides is maintained for 30 min. and that the integrity of the entire sound attenuator is maintained for 60 min.

Ventilation ducts must be run and designed so that in the event of a fire they will not give rise to ignition in nearby elements of structure and permanent fittings outside the fire compartment in which they are situated, during the period stated in the fire compartment provision. Note that the sound attenuator cannot be installed running through a fire-separating element of structure.

Air treatment system installations that run through an element of structure separating fire compartments must be designed so that the fire-separating capability of the element will be maintained. **BBR 5:6521.**

According to **BBR 5:6213** Fire-resistance Class **EI** must be changed to Class **E**, if the distance to an escape route and to combustible material is sufficient so that it will not impair evacuation safety or increase the risk of fire spread. For ventilation ducts, this means that I-rated duct insulation can be replaced by an appropriate safety distance.

Safety distance means the shortest distance required so that heat radiation from a hot surface will not ignite combustible material or will not injure persons evacuating the building.

Generally, no safety distance is required for temperatures below 375° C.

The required safety distance specified in our catalogue has thus been calculated the parallel case (combustible material or persons parallel to the sound attenuator) since it is in this case that develops the most incident radiation.

Installation of sound attenuators in ducts to specific fire resistance class arranged at a safe distance to combustible material.

The fire-resistance class requirement of the sound attenuator is governed by the requirements that are applicable to the ventilation duct in which the sound attenuator is installed. The safety distance should be measured at right angles from the surfaces of the sound attenuator. The specified safety distance is based on a critical radiation level for ignition of 10 kW/m² (without pilot flame).

Installation of sound attenuators in ducts to specific fire resistance class with safety distance to persons evacuating a building

This refers to escape routes such as separate stairways in a building or separate corridors within a hotel floor level. Besides the sound attenuator's surface temperature and emissivity, the exposure time that evacuating persons have to endure governs the need for a safety distance and the length of this gap to evacuating persons. The Swedish Board of Housing, Building and Planning Regulation for New Building no. BBR 5:6213, advises: "the distance to evacuating persons should be so far that the radiation level will not exceed 3 kW/m². Higher radiation levels may be acceptable if the time aspects for evacuation and combustion are observed". The 3 kW/m² limit is based on the limit value for unendurable pain during a long period of exposure.

The safety distance shall be measured at right angles from the surfaces of the sound attenuator. The specified safety distance is based on a critical radiation level of 3 kW/m² and an emissivity of 1. Emissivity 1 has been chosen with regard to surface finish such as a painted finish or ageing. The end walls are not taken into account since a sound attenuator is normally installed so that the parallel case cannot arise.

SORDO-A (with 50 mm thick rock wool)

The SORDO-A has been granted type approval (TG 0783) for Fire-resistance Classes EI30/E60 and EI60 on condition that the tabulated safety distance to flammable material and/or persons in an escape route is complied with.

In the cases in which the safety distance to flammable material and/or persons in an escape route is not complied with, the SORDO-A then has Fire-resistance Class EI30/E60.

SORDO-B, -C (with 100 mm thick rock wool)

The SORDO-B, -C has been granted type approval (TG 0783 + 0784) for Fire-resistance Classes EI30/E60, EI60/EI20 and EI120 on condition that the tabulated safety distance to flammable material and/or persons in an escape route is complied with.

In the cases in which the safety distance to flammable material and/or persons in an escape route is not complied with, the SORDO-B, -C then has Fire-resistance Class EI60/EI20.

SORDO-P, -PF (with 100 mm thick mineral wool with aerodynamic centre body)

SORDO-P conforms to Fire resistance Class E60

Sizing

Sound attenuation

Sound attenuation is specified to ISO 7235, i.e. static integral attenuation for duct products.

The sound pressure level in rooms or outdoors can be calculated manually or by means of the Swegon ProAc Acoustic calculation software. ProAc enables you to make a complete acoustic calculation from the air handling unit to rooms and also plan individual products. ProAc provides full documentation for sound attenuation, sound generation and dimensions. ProAc can be downloaded from our website on the Internet.

Pressure drop

The net area is less than the connection diameter for improved sound attenuation data (especially in the low frequencies). The pressure drop that SORDO duct-to-duct installation generates is specified in Diagram 1.

The specified data is based on a uniform air stream in and out of the product. Any dampers, duct bends or other products in the ducting near the sound attenuator will increase its pressure drop and level of flow-generated sound, and affect its sound attenuating properties.

Diagram 1. Airflow – pressure drop, SORDO-A, C

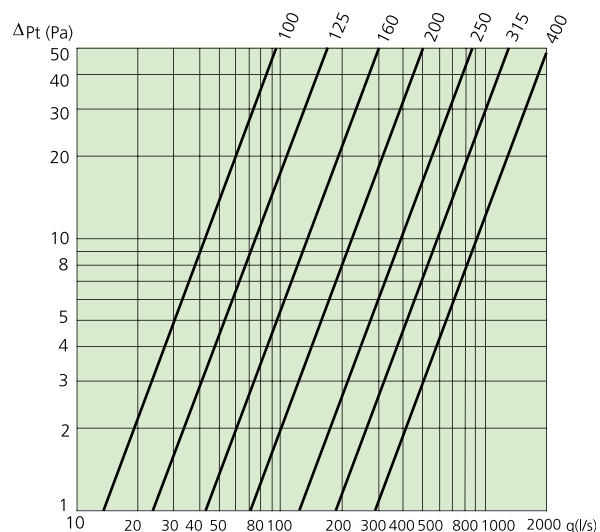

Table for the SORDO-A dimension print

Size mm	Ø d mm	Ø D mm	C mm	Length mm		
100	99	205	45	500	800	1100
125	124	226	45	500	800	1100
160	159	255	45	500	800	1100
200	199	288	45	500	800	1100
250	249	345	45	500	800	1100
315	314	403	45	500	800	1100
400	399	479	60	500	800	1100

Table for the SORDO-B dimension print

Size mm	Ø d mm	Ø D mm	C mm	Length mm		
315	314	482	45	500	800	1100
400	399	558	60	500	800	1100
500	499	700	60		900	1200
630	629	830	60		900	1200
800	799	1000	60		900	1200

Table for the SORDO-C dimension print

Size mm	Ø d mm	Ø D mm	C mm	Length mm		
100	99	284	45	500	800	1100
125	124	305	45	500	800	1100
160	159	334	45	500	800	1100
200	199	367	45	500	800	1100
250	249	424	45	500	800	1100
315	314	482	45	500	800	1100
400	399	558	60	500	800	1100

Table for the SORDO-P, PF dimension print

Size mm	Ø d mm	Ø D mm	C mm	Length mm	
500	499	700	60	900	1200
630	629	830	60	900	1200
800	799	1000	60	900	1600
1000	999	1200	60	1000	2000
1250	1249	1450	60	1200	2400
1600	1599	1800	60	1600	3200
2000	1999	2200	60	2000	4000

SORDO-A

Version (with 50 mm thick mineral wool)

The new SORDO is an industrially fabricated product designed for excellent sound attenuation and ease of installation. There are two different patent applications; one relating to the end wall and the other relating to our new fibre-migration-proof lining, inside the sound attenuator.

The standard SORDO is made of galvanised sheet steel.

The connection spigots are fitted with rubber seal rings. Type-approved to Tightness Class D.

The fire-resistance class is met by providing adequate safety distance.

The TBDA has been granted type approval (TG 0783) for Fire-resistance Classes EI30/E60, EI60/E60 provided that the safety distance required is complied with.

In the cases in which the safety distance to flammable material and/or persons in an escape route is not complied with, the SORDO-A then has Fire-resistance Class EI30/E60.

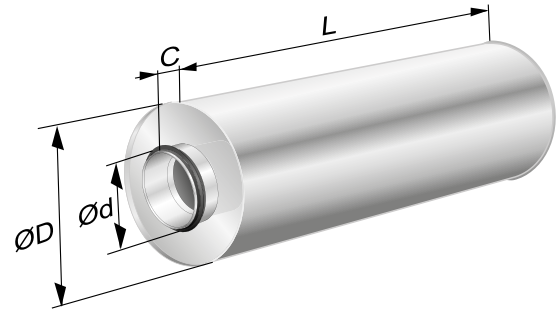

Figure 2. SORDO-A – Dimension print

The new SORDO is 100 mm shorter, with the same excellent acoustic data as before.

The overall dimension for connection sizes 100 up to and including 400 is shorter than previously.

The same degree of attenuation is made possible by, among others, reduced inner and outer diameters.

This reduces its weight and above all saves space.

SORDO-A, Acoustic Data

Size	Length (mm)	Ø d (mm)	Ø D (mm)	Static integral attenuation, dB to ISO 7235								Weight (kg)	Safety distance in mm	
				63	125	250	500	1K	2K	4K	8K		EI30	EI60
100	500	99	205	5	7	12	24	37	45	35	24	3,4	-	50
	800	99	205	6	10	19	32	45	50	45	27	5.1	-	50
	1100	99	205	7	12	26	40	50	50	50	38	6.8	-	50
125	500	124	226	3	6	10	21	30	37	32	17	3.8	-	50
	800	124	226	4	9	16	30	40	50	38	25	5.7	-	50
	1100	124	226	5	12	21	39	50	50	44	33	7.8	-	50
160	500	159	255	3	5	10	17	25	32	17	14	4,5	-	50
	800	159	255	4	8	15	25	35	42	28	20	6.7	-	50
	1100	159	255	5	11	20	33	46	50	39	25	9	-	50
200	500	199	288	3	3	8	13	18	22	13	12	5.2	-	50
	800	199	288	3	5	11	20	30	35	20	17	7.9	-	50
	1100	199	288	4	7	15	27	42	48	27	19	10.5	-	50
250	500	249	345	2	2	5	10	16	15	8	6	6.6	-	50
	800	249	345	2	4	8	15	23	24	12	9	9.8	-	50
	1100	249	345	3	6	11	20	31	34	17	11	13.1	-	50
315	500	314	403	1	3	4	7	10	7	6	2	7.9	-	50
	800	314	403	1	4	7	12	17	14	8	4	11.8	-	50
	1100	314	403	2	5	9	17	25	21	10	6	15.8	-	50
400	500	399	479	1	3	3	7	10	7	5	3	10.1	-	50
	800	399	479	1	3	5	11	15	10	6	3	14.8	-	50
	1100	399	479	2	4	7	15	20	13	7	3	19.6	-	50

SORDO-C

Version (with 100 mm thick mineral wool)

The new SORDO is an industrially fabricated product designed for excellent sound attenuation and ease of installation. There are two different patent applications; one relating to the end wall and the other relating to our new fibre-migration-proof lining, inside the sound attenuator.

The standard SORDO is made of galvanised sheet steel. The connection spigots are fitted with rubber seal rings. Type-approved to Ductwork leakage class D.

The fire-resistance class is met by providing adequate safety distance.

The SORDO-C has been granted type approval (TG 0783) for Fire-resistance Classes EI30/E120, EI60/E120 and EI120/E120 respectively on condition that the safety distance is complied with.

In buildings in which the safe distance from a combustible material and/or persons in an evacuation route is not complied with, the SORDO-C then has Fire-resistance Class EI60/E120.

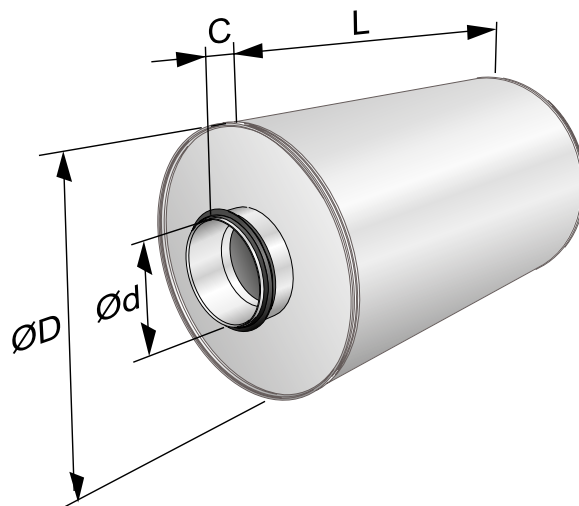

Figure 3. SORDO-C – Dimension print

The new SORDO is 100 mm shorter, with the same excellent acoustic data as before.

The overall dimension for connection sizes 100 up to and including 400 is 100 mm shorter than previously. The same degree of attenuation is made possible by, among others, reduced inner and outer diameters.

This reduces its weight and above all saves space.

SORDO-C, Sound attenuation

Size	Length (mm)	Ø d (mm)	Ø D (mm)	Static integral attenuation, dB to ISO 7235								Weight (kg)	Safety distance in mm	
				63	125	250	500	1K	2K	4K	8K		EI60	EI120
100	500	99	284	7	10	15	28	41	48	37	25	6.1	-	50
	800	99	284	8	13	22	36	49	50	47	28	9	-	50
	1100	99	284	9	15	29	44	50	50	50	39	12	-	50
125	500	124	305	5	9	13	25	34	40	34	18	6.7	-	50
	800	124	305	6	12	19	34	44	50	40	26	10	-	50
	1100	124	305	7	15	24	43	50	50	46	34	13.3	-	50
160	500	159	334	5	8	13	21	29	35	19	15	7.7	-	50
	800	159	334	6	11	18	29	39	45	30	21	11.3	-	50
	1100	159	334	7	14	23	37	50	50	41	26	15	-	50
200	500	199	367	5	6	11	17	22	25	15	13	8.7	-	50
	800	199	367	5	8	14	24	34	38	22	18	12.9	-	50
	1100	199	367	6	10	18	31	46	51	29	20	17.1	-	50
250	500	249	424	4	5	8	14	20	18	10	7	10.5	-	50
	800	249	424	4	7	11	19	27	27	14	10	15.5	-	50
	1100	249	424	5	9	14	24	35	37	19	12	20.6	-	50
315	500	314	482	3	6	7	11	14	10	8	3	12.3	-	50
	800	314	482	3	7	10	16	21	17	10	5	18.2	-	50
	1100	314	482	4	8	12	21	29	24	12	7	24.1	-	50
400	500	399	558	3	6	6	11	14	10	7	4	15.2	-	50
	800	399	558	3	6	8	15	19	13	8	4	22.2	-	50
	1100	399	558	4	7	10	19	24	16	9	4	29,3	-	50

SORDO-B

Version (with 100 mm thick rock wool)

The standard SORDO-B is made of galvanised sheet steel. Sound attenuating material consisting of 100 mm thick long-fibred, compressed rock wool lined with EUROLON. EUROLON withstands substantially higher air velocities and mechanical strain than that in other makes of ordinary staple fibre. The sound attenuating material is also covered with perforated sheet steel outside the EUROLON layer. The connection spigots are fitted with rubber seal rings.

The SORDO-B has been granted type approval (TG 0784) for Fire-resistance Classes EI30/E120, EI60/E120 and EI120/E120 respectively on condition that the safety distance is complied with.

In buildings in which the safe distance from a combustible material and/or persons in an evacuation route is not complied with, the SORDO-B then has Fire-resistance Class EI60/E120.

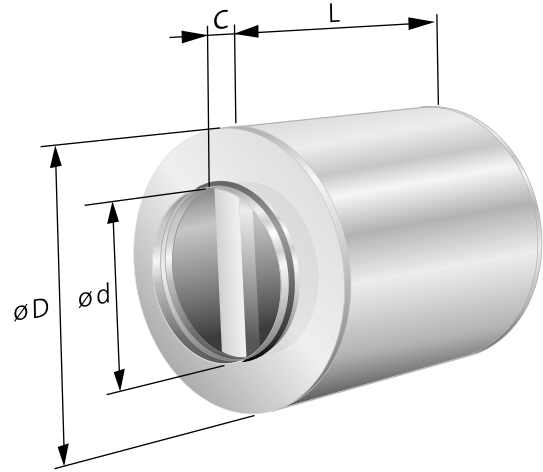
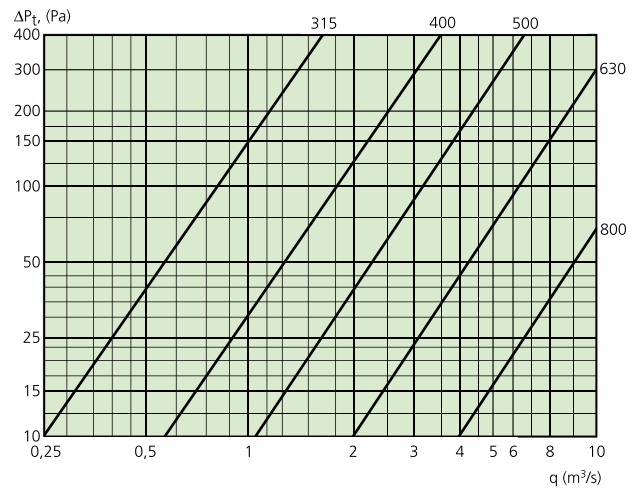

Figure 4. SORDO-B – Dimension print

Pressure drop

The pressure drop that SORDO-B duct-to-duct installation generates is specified in Diagram 2.

Diagram 2. Pressure drop – Airflow, SORDO - B



SORDO-B, Sound attenuation

Size	Length (mm)	Ø d (mm)	Ø D (mm)	Static integral attenuation, dB to ISO 7235								Weight	Safety distance in mm	
				63	125	250	500	1K	2K	4K	8K		EI60	EI120
315*	500	314	482	4	8	10	17	24	28	19	11	13.1	-	50
	800	314	482	4	9	13	22	31	35	21	13	19.3	-	50
	1100	314	482	5	10	15	27	39	42	23	15	25.6	-	50
400*	500	399	558	4	8	9	17	24	28	18	12	16.1	-	50
	800	399	558	4	8	11	21	29	31	19	12	23.5	-	50
	1100	399	558	5	9	13	25	34	34	20	12	31	-	50
500	900	499	700	3	5	10	20	29	24	18	17	50.6	-	200
	1200	499	700	3	7	13	25	35	30	21	19	63.2	-	200
630	900	629	830	3	4	8	14	19	19	13	12	80.7	-	200
	1200	629	830	4	6	12	17	21	24	17	16	94.9	-	200
800	900	799	1000	1	2	5	11	12	14	8	9	88.8	-	200
	1200	799	1000	1	3	7	13	14	18	11	10	101.5	-	200

*= version similar to SORDO-C, with centre baffle

SORDO-P

Version (with 100 mm thick mineral wool)

The SORDO-P is an industrially fabricated product designed for excellent sound attenuation in large ducts with circular connections.

The SORDO-P is equipped with an aerodynamically designed centre body (pod) for optimal acoustic and pressure-drop characteristics.

The sound attenuating material consists of 100 mm thick long-fibred mineral wool that offers excellent sound attenuation, especially in the mid-frequencies. The insulation is covered with EUROLON.

The sound attenuating material is also covered with perforated sheet steel outside the EUROLON layer.

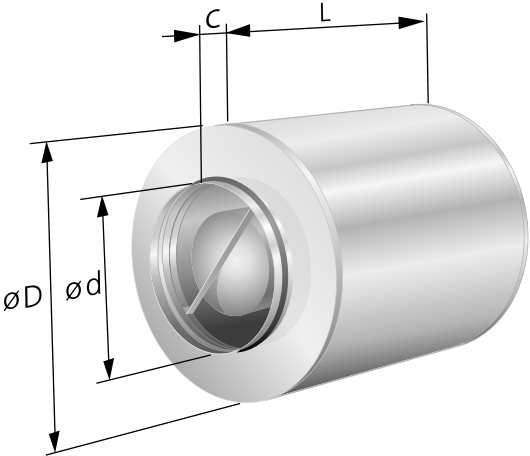
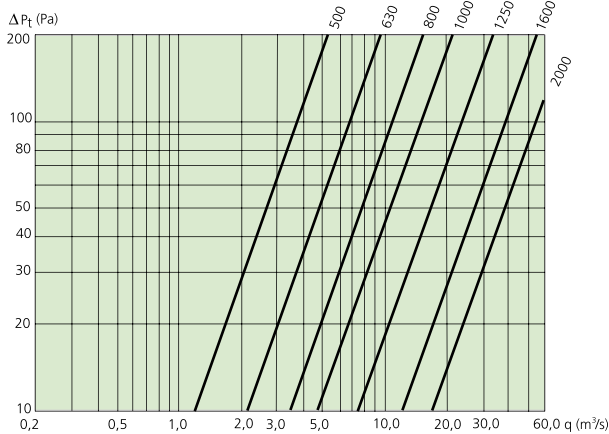

Figure 5. SORDO-P – Dimension print

The standard SORDO-P is made of galvanised sheet steel. The connection spigots are equipped with rubber seal rings.

The SORDO-P conforms to Fire-resistance Class E60.

Diagram 3. Pressure drop – Airflow, SORDO -P, -PF (Pa/m)



Pressure drop

The pressure drop that SORDO-P, -PF duct-to-duct installation generates is specified in Diagram 3.

SORDO P, Sound attenuation

Size	Length (mm)	Ø d (mm)	Ø D (mm)	Static integral attenuation, dB to ISO 7235								Weight
				63	125	250	500	1K	2K	4K	8K	
500	900	499	700	2	5	12	22	33	27	17	15	50,5
	1200	499	700	3	6	15	28	41	30	19	17	60,5
630	900	629	830	2	4	11	19	25	19	12	8	58
	1200	629	830	3	5	14	25	33	22	14	10	77
800	900	799	1000	1	3	9	17	21	15	9	6	69
	1600	799	1000	2	4	12	22	29	18	11	8	84
1000	1000	999	1200	1	3	9	17	20	15	9	6	96
	2000	999	1200	3	7	17	27	36	29	17	13	173
1250	1200	1249	1450	1	3	9	17	20	12	7	4	150
	2400	1249	1450	3	8	18	27	33	25	14	11	260
1600	1600	1599	1800	2	4	10	17	20	22	6	3	230
	3200	1599	1800	3	8	17	26	32	22	11	9	425
2000	2000	1999	2200	2	4	9	16	19	22	5	3	320
	4000	1999	2200	3	8	15	23	30	20	9	7	600

SORDO-PF

Version (with 100 mm thick mineral wool)

The SORDO-PF is an adaptation of the SORDO-P. The difference is that it has tapped holes for connection of flanges instead of connection spigots.

The technical data is the same as for the SORDO-P (see previous page)

Accessory

The SORDO T1 counterflange is a robust flange made of flat steel that has then been galvanised. The dimensions are adapted to DIN 24 154 Parts 2 and 5 German Standard. The counterflange can be fitted on both spiral-fold and longitudinal-fold ducts.

Oval bult holes facilitate installation.

Special

The SORDO can be supplied in various material qualities and material thicknesses. For further particulars, get in touch with your nearest Swegon representative.

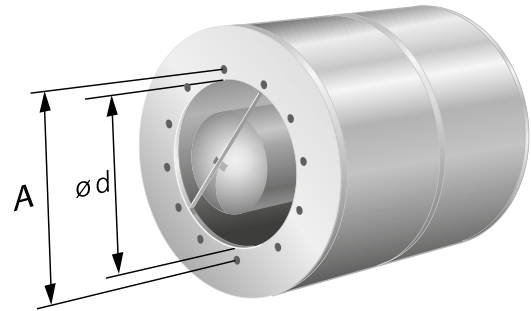

Figure 6. SORDO-PF – Dimension print

Dimensions for flange connection (mm)

Size Ød	Centre dimension A (mm)	Number of tapped holes	Hole dimension
500	541	12	M8
630	674	16	M10
800	837	24	M10
1000	1043	24	M10
1250	1311	24	M10
1600	1637	32	M10
2000	2073	40	M8

Ordering Key

Product

Circular sound attenuators

SORDO	aa-	bbbb-	cccc
Type: A, B, C, P, PF			
Connection dimensions: For SORDO A, -C 100, 125, 160, 200, 250, 315, 400 For SORDO-B 315, 400, 500, 630, 800 For SORDO-P, -PF 500, 630, 800, 1000, 1250, 1600, 2000			
Length: For SORDO-A, -C, 500, 800, 1100 For SORDO-B (dim. 315+400) 500, 800, 1100 (dim 500+630+800) 900, 1200 For SORDO-P, -PF (dim. 500+630) 900, 1200 (dim 800) 900, 1600 (dim. 1000) 1000, 2000 (dim. 1250) 1200, 2400 (dim. 1600) 1600, 3200 (dim. 2000) 2000, 4000			

Accessory

Counterflange (supplied in pairs)	SORDO T1
--------------------------------------	----------

Specification Text

Example of a specification text conforming to VVS AMA Standard.

Example 1

Swegon type SORDO-A round sound attenuators for connection to circular ducts, with the following functions:

- Self-supporting surface layer
- Fire-resistance Class EI30
Fire-resistance Class EI60 with safety distance of 50mm
- 50 mm thick rock wool

Designation:	SORDO-A 200-800	xx items
--------------	-----------------	----------

Example 2

Swegon type SORDO-B round sound attenuators for connection to circular ducts, with the following functions:

- Equipped with acoustic centre baffle
- Fire-resistance Class EI60
Fire-resistance Class EI120 with safety distance of 50mm
- 100 mm thick rock wool

Designation:	SORDO-B 400-1100	xx items
--------------	------------------	----------

Example 3

Swegon type SORDO-C round sound attenuators for connection to circular ducts, with the following functions:

- Self-supporting surface layer
- Fire-resistance Class EI60
Fire-resistance Class EI20 with safety distance 50 mm
- 100 mm thick rock wool

Designation:	SORDO-C 160-500	xx items
--------------	-----------------	----------

Example 4

Swegon type SORDO-P round sound attenuators for connection to circular ducts, with the following functions:

- Equipped with aerodynamic centre body (pod)
- With connection spigots
- 100 mm thick rock wool

Designation:	SORDO-P 630-1200	xx items
--------------	------------------	----------

Example 5

Swegon type SORDO-PF round sound attenuators for connection to circular ducts, with the following functions:

- Equipped with aerodynamic centre body (pod)
- With flange connection
- 100 mm thick rock wool
- Counterflange (supplied in pairs)

Designation:	SORDO-PF 630-1200	xx items
	SORDO-T1 630	xx items