

# GLOBAL LP OUT

Flat roof outdoor mounted ventilation unit with plate heat exchanger - TAC5

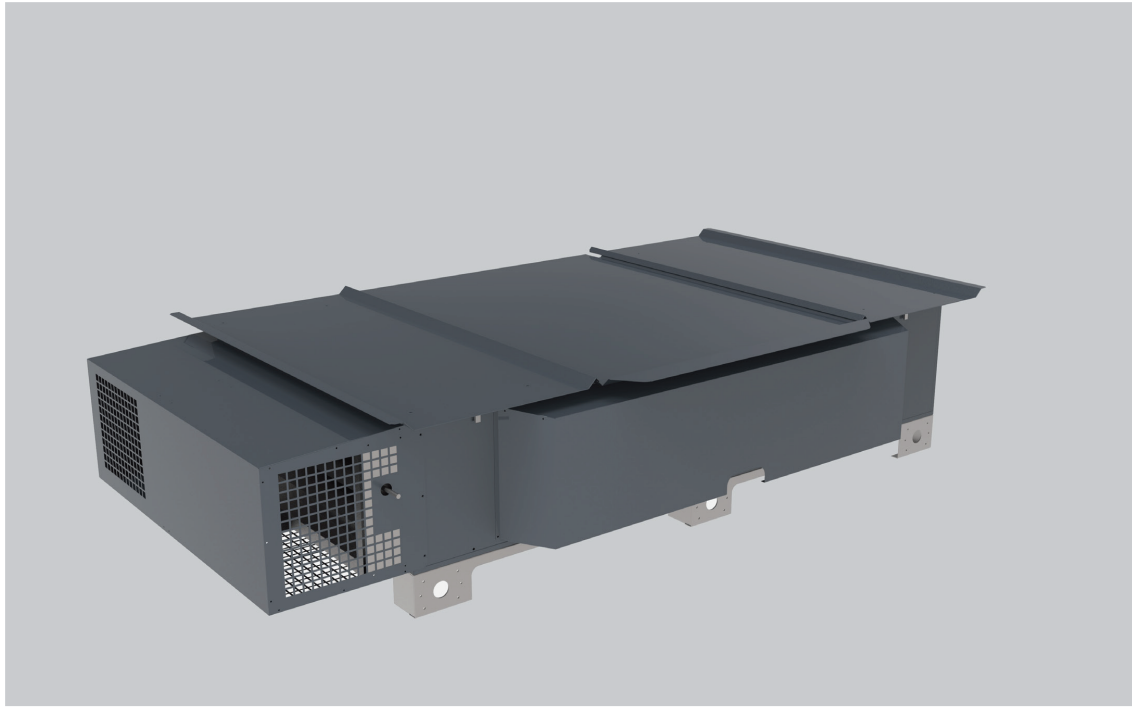

Ventilation unit with plate heat exchanger for commercial applications.  
Well-suited for both newly constructed buildings and renovation projects

Available in 2 sizes : LP OUT 08 ( 1420 m<sup>3</sup>/h) and LP OUT 10 (1800 m<sup>3</sup>/h)

Temperature efficiency: up to 85 %

For installation outdoors/indoors : flat roof/on the ground

Premium control technique with touchscreen HMI

**Swegon** 

T 0320 - 28 61 81 | [www.auerhaan-klimaattechnik.nl](http://www.auerhaan-klimaattechnik.nl)

Als het om lucht gaat.

  
**AUERHAAN**  
KLIMAATTECHNIEK



## THE MOST IMPORTANT POINTS

### DOUBLE FLOW HIGH PERFORMANCE VENTILATION UNITS

Given that each project has unique parameters and caters for different requirements, it follows that there can be no universal, 'one-size-fits-all' unit. This is why Swegon offers an unrivalled range of air handling units. Whether your project is large-scale or small-scale, whether it calls for basic or advanced products, whether the expectations regarding sound levels or space efficiency are tough to meet, we have a solution to match your requirements. In other words, we have the perfect unit for your project.

The company opted for the systematic integration of fans equipped with high performance DC motors (TAC technology). With this technology, the GLOBAL line anticipated the most demanding levels of energy requirements to come, such as those set by the new standards ErP2018.

Over time, it has developed more extensive and effective control. The most recent (TAC) is at the forefront of the technology, due both to its internal functionality and its opening via communication (Modbus, TCP/IP, BACnet, KNX).

### PLUG-AND-PLAY UNITS

The GLOBAL LP OUT ventilation units are supplied as plug and play devices. The basic functions are pre-programmed and most of the accessories are pre-installed, pre-wired and pre-configured in factory. Once the remote control module has been connected, all that needs to be done is to switch the unit on and to change the pre-configured parameters if needed.

### ACCESS – FOR OPERATORS

The units' generously sized doors ensure good access for maintenance work.

### PLATE HEAT EXCHANGER

The exchanger is a high efficiency (>80%) air/air plate heat exchanger, made of seawater-resistant aluminium. The exchanger complies with standard EN 308 and is Eurovent certified.

### HIGH-PERFORMANCE FANS

The powerful EC fans ensure that sufficient external pressure is available, even with high airflows. The composite fan blades will ensure a better SFP and a higher fan efficiency, compared to aluminum fan blades. The efficiency level fulfills the ErP2018 requirements.

### SUMMER AND NIGHT TIME COOLING

A 100% bypass is a standard feature on the GLOBAL units equipped with plate heat exchangers. It allows us to ensure the freecooling function and is automatically controlled on the indoor and outdoor temperatures.

### HEATER ELEMENTS

The GLOBAL LP OUT units can be factory-fitted with an integrated water post heating or electric pre- or post heater element. The capacity of coil is modulated in order to maintain the setpoint. The water heating coil is ready-to-connect and delivered with a 3-way valve controlled by the TAC controller. The built in control system allows for all GLOBAL units to control an additional external heating (electric or water) and/or cooling exchanger.

### DAMPERS

The GLOBAL units can be equipped with supply air and exhaust air dampers. In this case, the TAC control activates a fan start-up delay when the unit is started. As an option, a spring return actuator is available.

### AIR FILTERS – FILTER CLASSES

As standard, the GLOBAL LP OUT ventilation units are fitted with particularly effective and large-scale particulate matter bag filters, with filter class F7(EN779) / ePM1≥70% (ISO16890) for the supply air and M5 (EN779) / ePM10≥50% (ISO16890) for the exhaust air.

### CONTROL MODULES

The integrated TAC control system can be connected to: **TACTouch HMI** with 4,3" capacitive touchscreen. For configuring and controlling the operation of a heat recovery unit.

**SAT MODBUS** for configuration, visual display and controlling the operation via MODBUS RTU.

**SAT KNX** for configuration, visual display and controlling the operation via KNX.

**TCP/IP module** for communication via the internet (MODBUS TCP/IP protocol) and the heat recovery devices. Embedded web pages are used for the configuration, visual display and controlling the operation.

**BACnet gateway** for configuration, visual display and controlling the operation via BACnet IP.

### OUTDOOR INSTALLATION

The GLOBAL LP OUT series is designed to be installed on a flat roof. The outdoor version includes a roof, top access and a 125 mm base, and optional additional legs (205 mm) for snow protection and direct connection to the building. An plenum for outside air admission and exhaust air is also available as an option.

The unit is delivered ready for use, fully pre-wired. A "TACTouch" remote control is available as an option, and is used to control the unit without opening it. Except the mounting of the roof and outdoor accessories, all you have to do is connect the voltage (outside the unit) and the "TACTouch" remote control, and configure the unit's operation. The unit includes a modulating bypass (100%) as standard and its control. It is designed to receive the installed options and control them according to your needs.

# GLOBAL LP OUT SERIES

## CONTROL OPTIONS



**Touchscreen HMI**



**BACnet gateway**



**MODBUS RTU / ETHERNET**

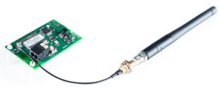

**WIFI**



**KNX**



**SAT3**

## AVAILABLE OPTIONS

- Internal electrical post heating coil (KWout)
- Internal electrical pre heating coil (KWin)
- Internal water post heating coil (IBA)
- External post heating/cooling coil (EBA)
- Motorised dampers (CT)
- Flexible sleeve 20mm (MS20)
- Flexible sleeve 30mm (MS30)

## MAIN ADVANTAGES

- EN1886 classification: T3 / TB2 / F9 / L2 / D1.
- High efficiency plate heat exchanger with Eurovent certification.
- Integrated pre- and post heating coil; electrical or water based. Fully integrated modulating capacity control.
- Innovative touchscreen interface with intuitive commissioning menu and integrated contextual aid.
- EC plug fans with composite blades for optimised efficiency and low noise levels. Aluminum fan blades available as an option.
- Easy access for maintenance. The unit can be opened without moving the roof and can be done by only one technician.
- RAL7016 galvanized steel sheet construction with 30mm mineral wool thermal insulation.
- Circular duct connections with rubber seal; standard slip clamp connections for rectangular connections.
- Plug-and-play prewired unit. The complete unit is pre-wired and pre-configured in factory.
- Optional accessories are delivered as separate components, to be installed and wired on site.
- Bag filters for both supply and extract air.  $ePM1 \geq 70\%$  for fresh air intake and  $ePM10 \geq 50\%$  for extract air.
- Proven TAC controller with pre-configuration.
- Max airflow of 1800 m<sup>3</sup>/h (500.04 l/s) for unit size "10".
- ERP2018 optimised design.
- Selection software available for free download.
- Standard VDI6022 developed.
- Installation on flat roofs.
- Direct elbow connection through flat roof.
- Snow base frame in option.
- Building architecture integrated design, flat profile.
- Appropriate for renovation projects.

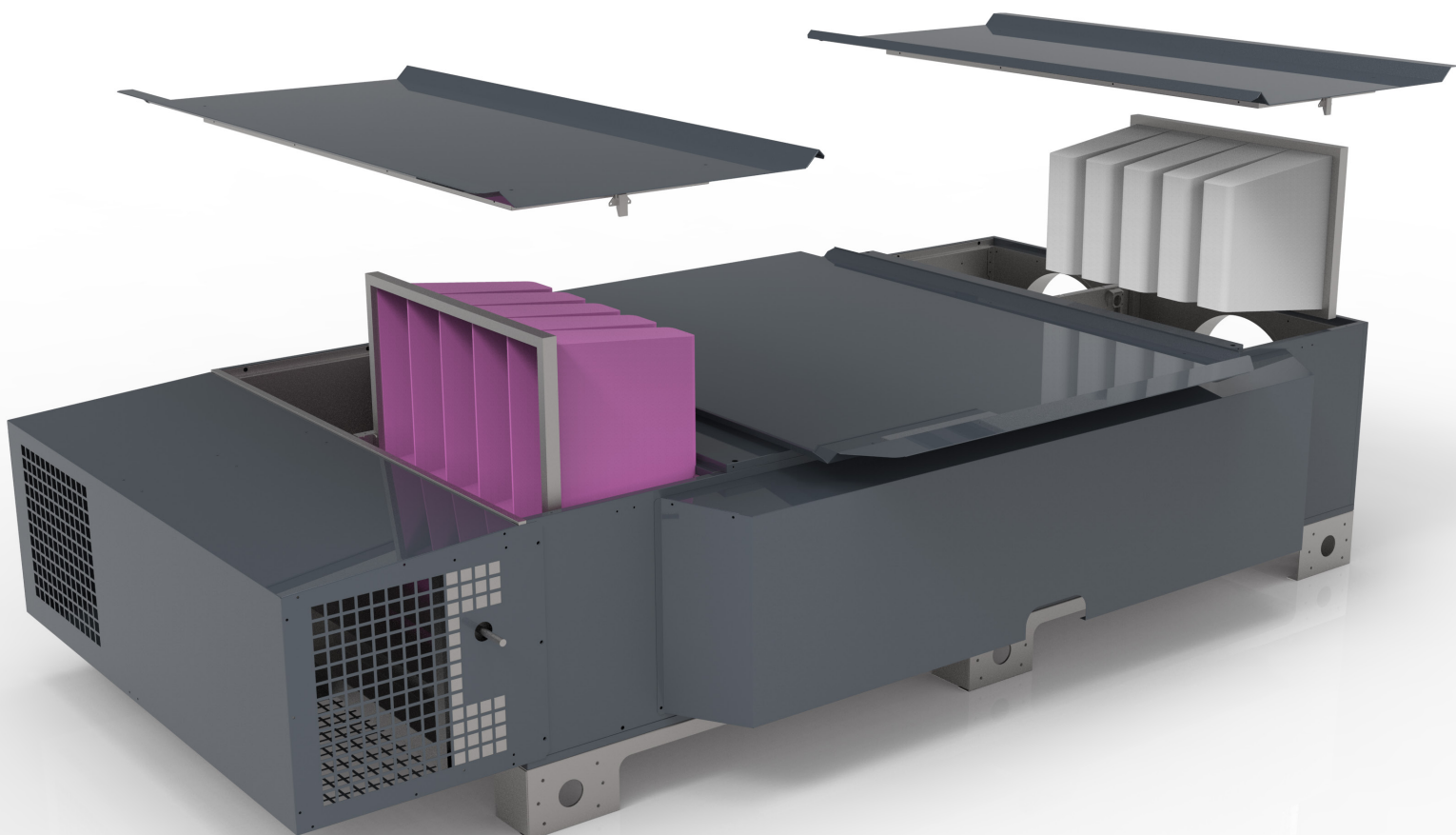

**THE CORRECT OPERATING MODE IS AN IMPORTANT FACTOR**

**AIRFLOW OR PRESSURE**

Whether the ventilation system is operated on the basis of constant pressure or constant airflow or via a 0–10V control system depends on the area of application and the specific on-site requirements. The integrated master/slave control system ensures that operation is always well-balanced.

**THE ADVANTAGES IN DETAIL**

- Sufficiently high external pressure
- Constant airflow
- Demand control: constant airflow controlled by a 0–10 V signal
- Constant pressure via an external pressure sensor

**Constant airflow mode**

A typical area of application is non-residential buildings, e.g. offices and business premises as well as schools, nurseries and sports halls with stable volumes of air.

**Demand control mode**

Alternatively, the airflow can be automatically adapted in line with the ventilation requirements and on a user-specific basis via the 0–10 V input, e.g. by means of a CO2 sensor, or the control system can be used via the customer's building service management/ instrumentation and control system.

**Constant pressure mode**

A prime example is undoubtedly apartment buildings with the opportunity to control the ventilation in individual apartments separately. The pressure remains constant even when the ventilation is increased or decreased in one apartment as required, by means of an airflow control unit. The airflow stays the same in all the other apartments, i.e. the ventilation system always runs within the ideal range. An external pressure sensor is required for constant pressure mode.

**THE 3 MAIN OPERATING MODES:**

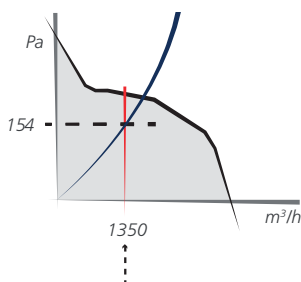

**Constant Airflow mode**

The airflow is kept constant, irrespective of external changes in pressure.

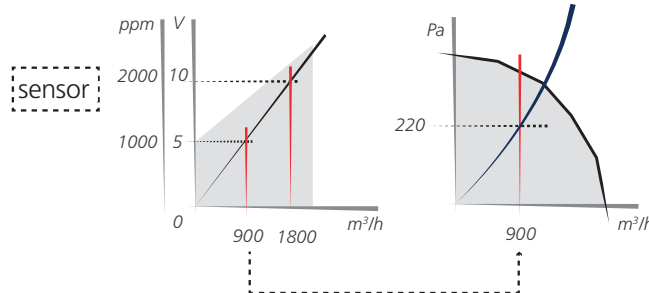

**Demand control mode**

**A linear voltage/airflow ratio.** The airflow can be regulated, e.g. by a CO2 sensor, via a 0–10 Volt signal.

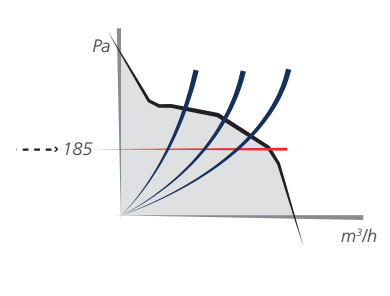

**Constant pressure mode**

The pressure is kept constant, irrespective of external changes in pressure. An external pressure sensor is required.

## Touchscreen REMOTE CONTROL

Remote control with touchscreen display and integrated timer with 4 actions per day and 'off day' functionality. For configuring and controlling the operation of 1 heat recovery unit. The commissioning menu, alarm history and maintenance menu are all of them focussed on

efficient operation.

### Article

TACtouch



## 4 POSITION SWITCH

With the four position switch, a unit can be switched to one its three configurable operating speeds and the off-position.

### Article

COM4



## SAT MODBUS

Interface for configuration, visual display and controlling the operation via MODBUS RTU

### Article

SAT MODBUS



## SAT ETHERNET

Interface for configuration, visual display and controlling the operation via MODBUS TCP/IP

### Article

SAT Ethernet



## BACnet gateway

For communicating with the heat recovery devices via a BACnet TCP/IP protocol. Up to four units can be integrated through the interface. The optional SAT Ethernet interface is required.

### Article

BACnet



## SAT Wifi

The Wifi interface with MODBUS TCP/IP, allows for a wireless connection to the air handling unit. Typically this accessory would be used in order to control the unit with the smart phone application.

### Article

SAT wifi



## SAT KNX

Interface for configuration, visual display and controlling the operation via KNX

### Article

SAT KNX



## SAT3

The SAT3 combined with the TAC controller allows signalling the following with 2 free of potential contacts: Fan is actually running and alarm on a pre-set pressure variation. This status is expressed by closing the contact.

### Article

SAT3



EC PLUG FAN WITH  
COMPOSITE FAN BLADES  
(ALUMINUM BLADES  
OPTIONAL) 1

FRESH AIR  
FILTER 2

INTEGRATED  
CONTROLLER 3

PREHEATING COIL  
(OPTION) 4

HIGH EFFICIENCY PLATE  
HEAT EXCHANGER 5

INTEGRATED POST  
HEATING -WATER/  
ELECTRICAL  
(OPTION) 6

STAINLESS STEEL  
DRAIN PAN 7

EXTRACT AIR  
FILTER 8

100% BYPASS 9

BOX I/O (INLET/OUTLET) 10

BASE FRAME 205MM  
(ACCESSORY) 11

PROTECTION COVER 12

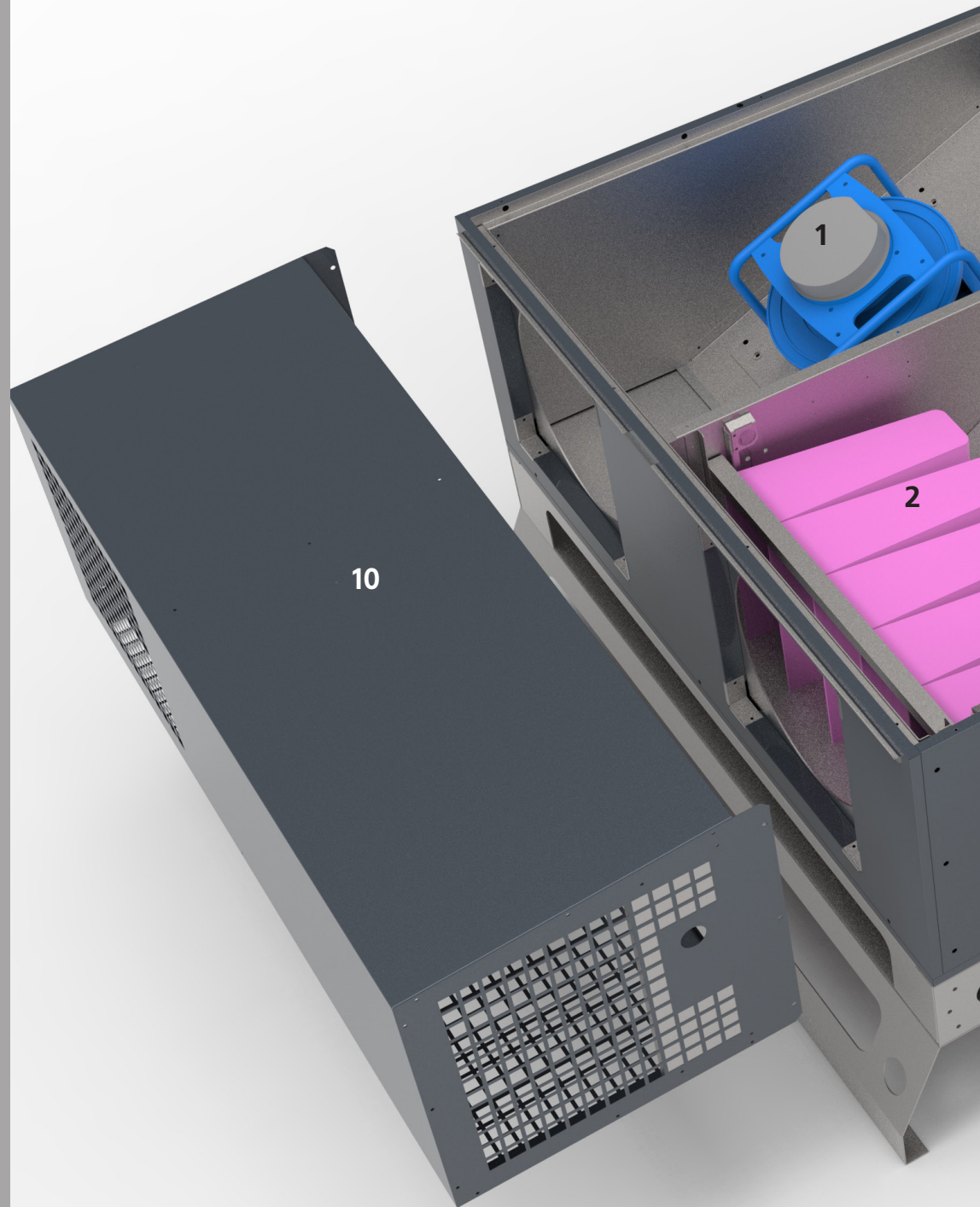



# GLOBAL LP OUT SERIES

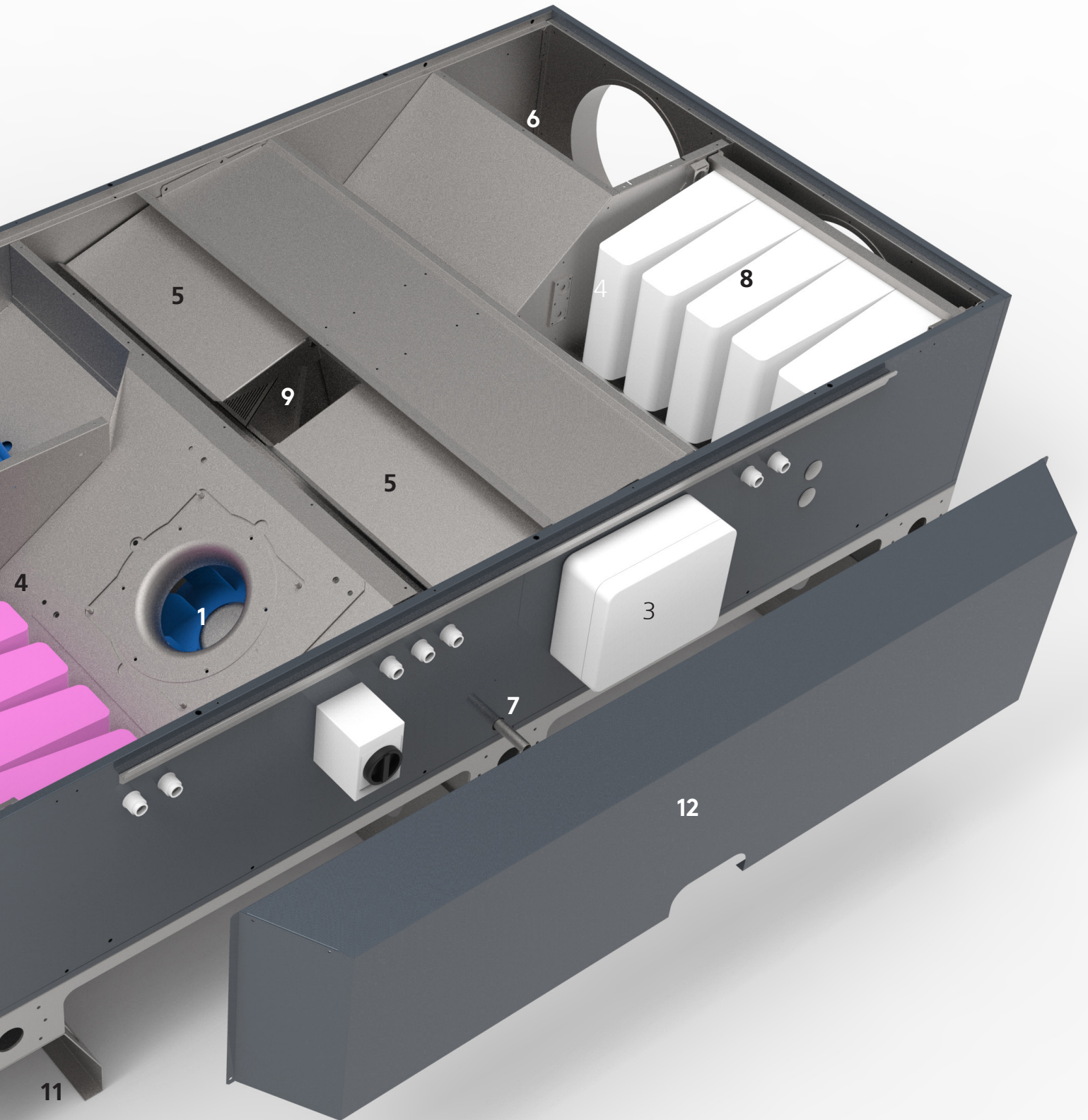

## GENERAL DESCRIPTION GLOBAL LP

### EC FANS WITH COMPOSITE FAN BLADE

As standard, the EC fans are equipped with composite fan blades. Optionally, aluminum fan blades are available. The advantage of the composite fan blades are lower weight and aerodynamical shaping of the blades. All of this is finally resulting in a better SFP value.

The fans are physically located on the cold air side of the plate heat exchanger, thus drastically reducing the emitted noise levels toward the occupied rooms in the building.

### CIRCULAR DUCT CONNECTIONS

The duct connections for sizes 08 are circular and with rubber sealing.

### RECTANGULAR DUCT CONNECTIONS

The duct connections for sizes 10 and up, are rectangular standardised 'slip clamp' duct connections.

### FILTERS

All GLOBAL LP OUT units size 08 and 10 are equipped with bag filters. The function of the filter is to keep both the air and the heat exchanger clean. The standard fresh air filter is of class F7(EN779) / ePM1 $\geq$ 70% (ISO16890)/ ePM10 $\geq$ 50% (ISO16890). An F7(EN779) / ePM1 $\geq$ 50% (ISO16890) filter on the extract air side is not available since this would have a negative influence on the energy consumption.

The filters are mounted in locking guide rails in order to facilitate removal and inspection. The filters guiderails are compliant to the requirements for filter bypass leakage to Class F9. The filter monitoring function is integrated in the standard configuration of the TAC controller.

### PLATE HEAT EXCHANGER

The plate heat exchanger is a heat exchanger with a temperature efficiency of up to 85% and is installed under an angle to facilitate the evacuation of condensate. The plate heat exchanger is eurovent certified.

### TAC CONTROLLER

The control equipment is completely integrated into the GLOBAL air handling unit. The controller controls and regulates the temperatures, airflows and other functions. The controller is pre-configured in factory with default settings.

### UNIT CASING

The casing of the GLOBAL LP OUT consists of metal panels. The outer skin is made of painted steel sheet, RAL7016. The inner skin is made of galvanized sheet steel. The panel thickness is 30mm with intervening insulation consisting of mineral wool. The panels can be easily removed for better access.

#### EN1886 casing performance:

Air leakage, class:	L2
Thermal bridges:	TB2
Thermal transmission:	T3
Mechanical strength:	D1

## ANTI FROST STRATEGY

Different antifreeze protection strategies are available for units with counterflow heat exchanger.

- Supply airflow reduction
- Bypass modulation
- Internal electrical preheating coil

## DEFROST STRATEGY

When the unit is used in cold climate conditions, a defrost option is available to avoid any risk linked to the icing of the plate heat exchanger.

TAC controller will monitor the pressure drop of the heat exchanger to activate the defrost function in case of pressure drop increase in the extract flow.

## INTERNAL ELECTRICAL PRE HEATING COIL - KW<sub>IN</sub>

The unit can be equipped with an internal electrical preheating coil. The coil is physically located between the fresh air filter and the supply air fan. The first function of the preheating coil is to protect the plate heat exchanger against freezing.

## INTERNAL WATER HEATING COIL - IBA

The unit can be equipped with an internal water heating coil. The coil is physically located between the plate heat exchanger and the supply air duct connection. The water coil has internal water connections and is delivered with flexible connections in order to connect

## INTERNAL ELECTRICAL HEATING COIL - KW<sub>OUT</sub>

The electrical post heating coil is physically located between the plate heat exchanger and the supply air duct connection. The electrical coil has two overheating protections, one with manual reset and one with automatic reset. When the electrical post heating coil is config-

## TOUCHSCREEN HMI

The hand-held user interface is a 4.3" touchscreen and is very user friendly. The HMI is rendering on-site commissioning intuitive and simple by means of the commissioning menu. The HMI is equipped with a 2 meter long connection cable and magnets. By means of the magnets, the HMI can be easily fixed on to any metallic surface.

The defrost function consists in stopping the supply flow for a short period of time.

it to the hydraulic system on the outside of the unit. The water coil is equipped with an anti-frost protection temperature sensor, which is mounted on the surface of the coil.

ured correctly, the coil is stopped immediately when the unit is stopped, however, the fans are kept running for 90 seconds in order to cool down the electrical coil.

# GLOBAL LP OUT 08

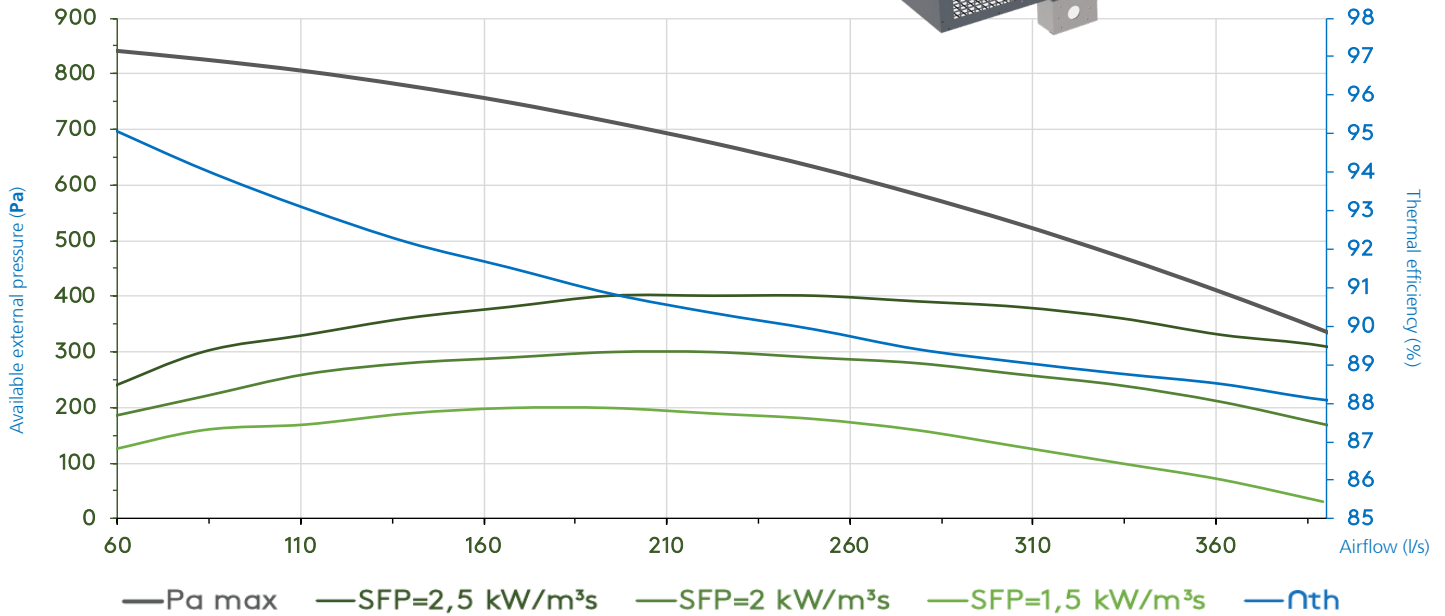
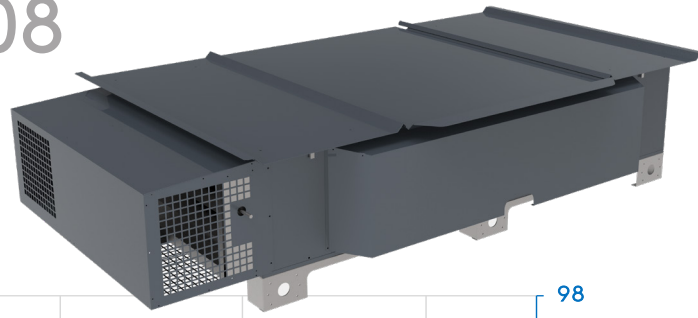

## GENERAL TECHNICAL SPECIFICATIONS

• AIR VOLUME	200 - 1420 m³/h
	55 - 395 l/s
• DIMENSIONS (W x D x H)	2540 x 1450 x 590
• WEIGHT	275 kg
• POWER CONNECTION	1 x 230 V/5.3 A
• RECOMMENDED FUSES	D6A - 10kA - AC3
• BAG FILTER FILTER CLASS EN16890	ePM1 70%/ePM10 50%
• DUCT CONNECTIONS SUPPLY/EXHAUST	Ø315
• DUCT CONNECTIONS EXTRACT/OUTDOOR	Ø315
• OPERATING RANGE	-20°C ... +40°C
• EN1886 CLASSIFICATION	T3/TB2/F9/L2/D1

AIRFLOW		ABSORBED POWER	SFP	THERMAL EFFICIENCY DRY	THERMAL EFFICIENCY WET	T° AFTER HEAT EX-CHANGER	SOUND PRESSURE
m³/h	l/s	W	kW/m³/s	%	%	°C	dB(A)
800	220	336	1,5	83,4	90,3	18,2	37,2
1100	306	524	1,7	81,0	89,0	17,7	38,6
1300	361	697	1,9	79,9	88,9	17,5	39,4
1450	400	824	2,1	79,4	88,0	17,3	40,4

Conditions :

1. All values at 200Pa external pressure.
2. T° after heat exchanger at -10°C, 90%RH and +22°C, 50% HR.
3. Thermal efficiency at -10°C, 90%RH and +22°C, 50% HR.
4. Sound pressure for ducted unit in free field conditions at 3m.
5. All data for composite fans variant

DIMENSIONS (mm)

GLOBAL LP OUT 08

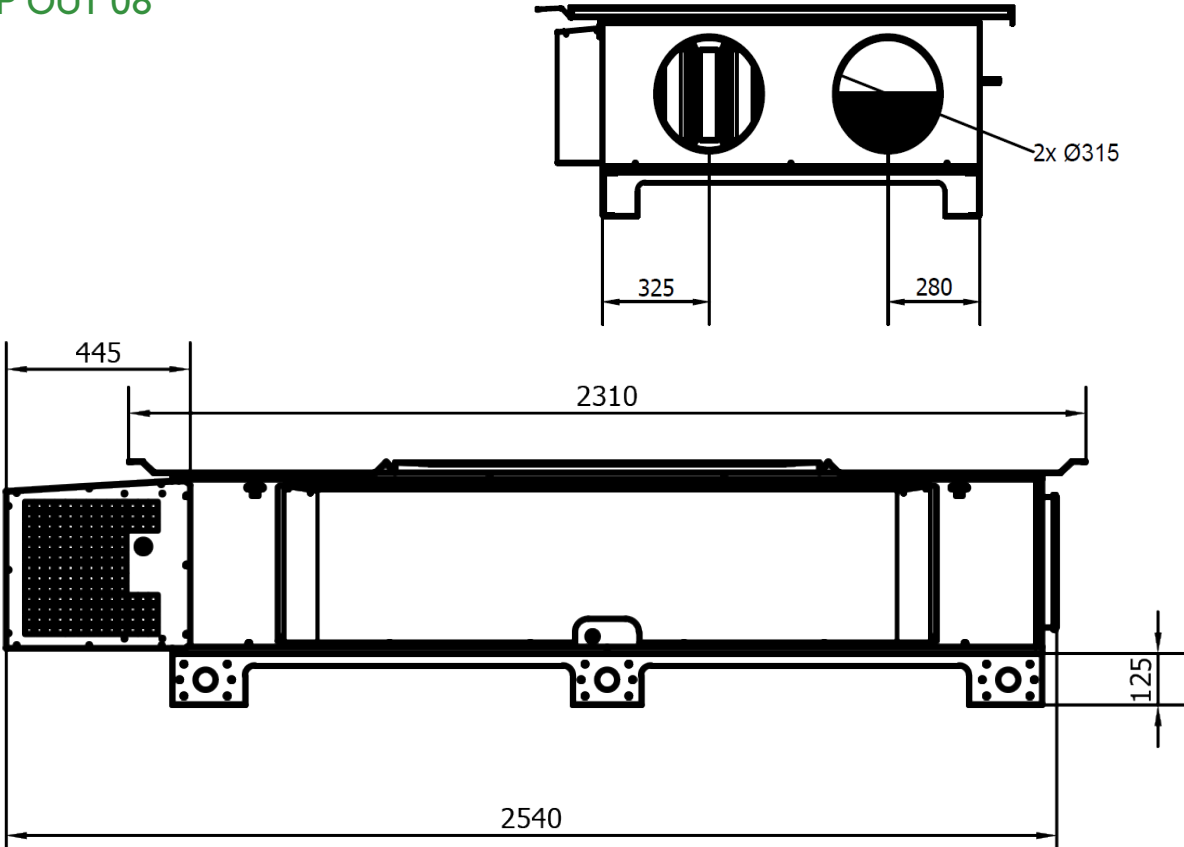

GLOBAL LP OUT 08

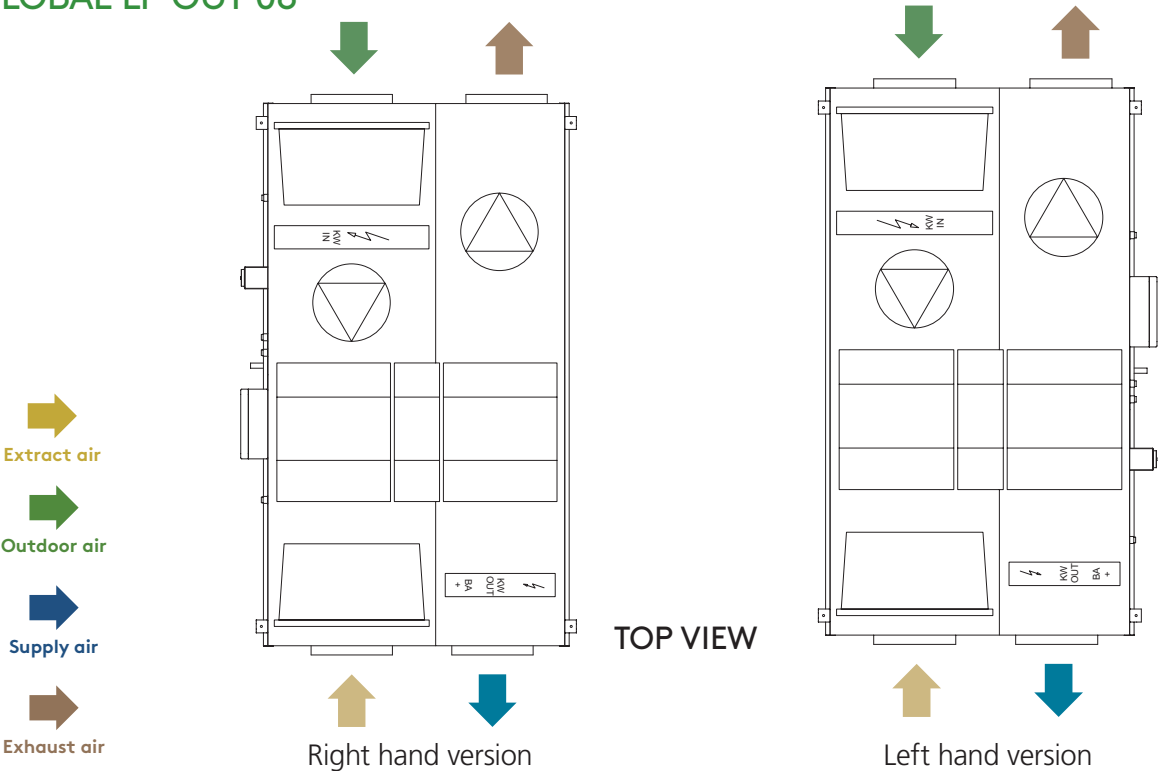

# GLOBAL LP OUT 10

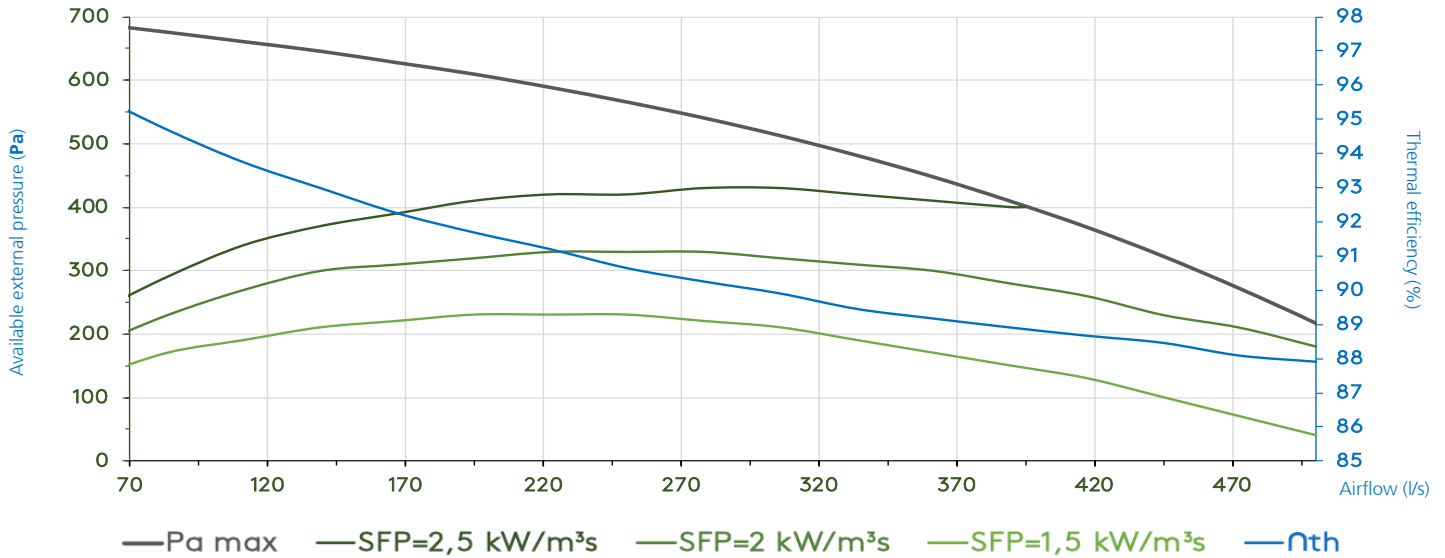
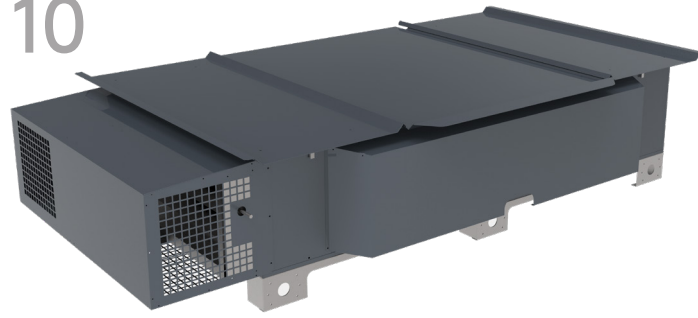

## GENERAL TECHNICAL SPECIFICATIONS

• AIR VOLUME	250 - 1800 m³/h
	70 - 500 l/s
• DIMENSIONS (W x D x H)	2540 x 1750 x 590
• WEIGHT	335 kg
• POWER CONNECTION	1 x 230 V / 4.9 A
• RECOMMENDED FUSES	D6A - 10kA - AC3
• BAG FILTER FILTER CLASS EN16890	ePM1 70%/ePM10 50%
• DUCT CONNECTIONS SUPPLY/EXHAUST	400 x 300
• DUCT CONNECTIONS EXTRACT/OUTDOOR	800 x 300
• OPERATING RANGE	-20°C ... +40°C
• EN1886 CLASSIFICATION	T3/TB2/F9/L2/D1

AIRFLOW		ABSORBED POWER	SFP	THERMAL EFFICIENCY DRY	THERMAL EFFICIENCY WET	T° AFTER HEAT EX-CHANGER	SOUND PRESSURE
m³/h	l/s	W	kW/m³/s	%	%	°C	dB(A)
900	250	332	1,3	84,0	90,7	18,4	35,5
1300	361	560	1,6	81,4	89,2	17,8	38,3
1700	472	911	1,9	79,6	88,1	17,3	42,1
1850	510	956	2,0	79,1	87,8	17,3	42,4

Conditions :

1. All values at 200Pa external pressure.
2. T° after heat exchanger at -10°C, 90%RH and +22°C, 50% HR.
3. Thermal efficiency at -10°C, 90%RH and +22°C, 50% HR.
4. Sound pressure for ducted unit in free field conditions at 3m.
5. All data for composite fans variant

DIMENSIONS (mm)

GLOBAL LP OUT 10

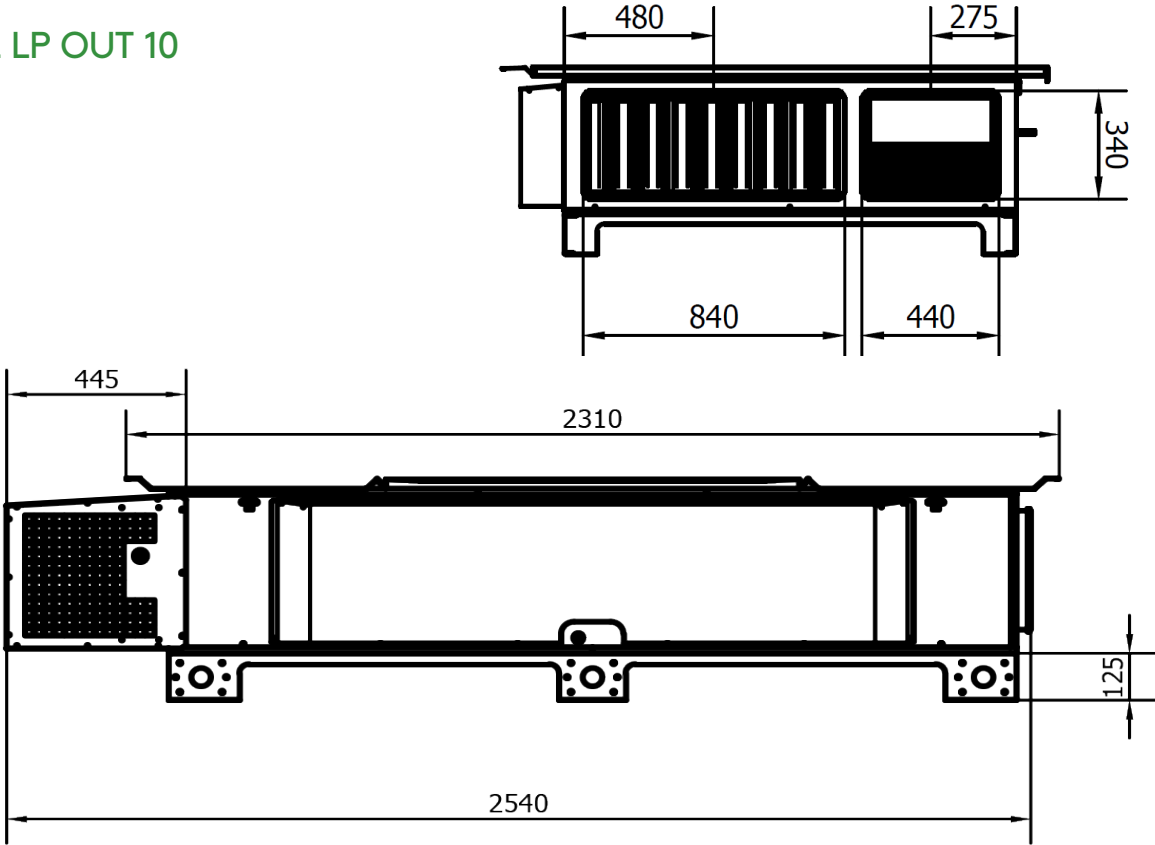

GLOBAL LP OUT 10

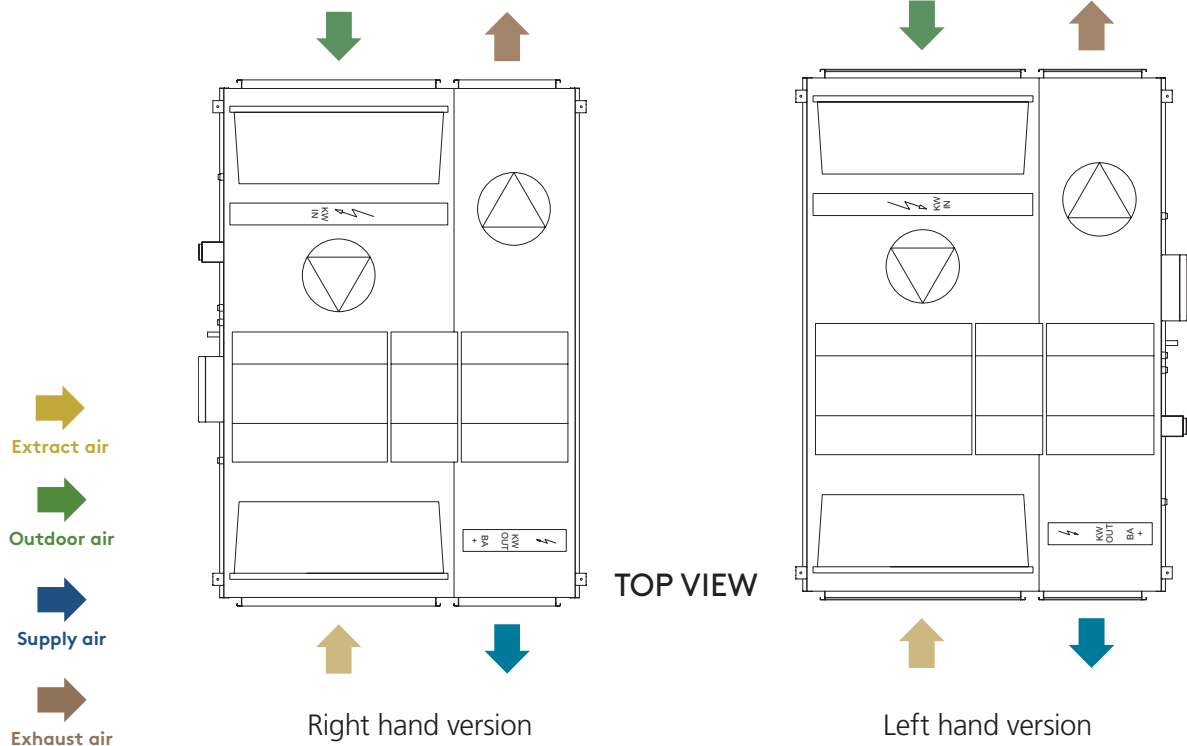

## GLOBAL LP OUT

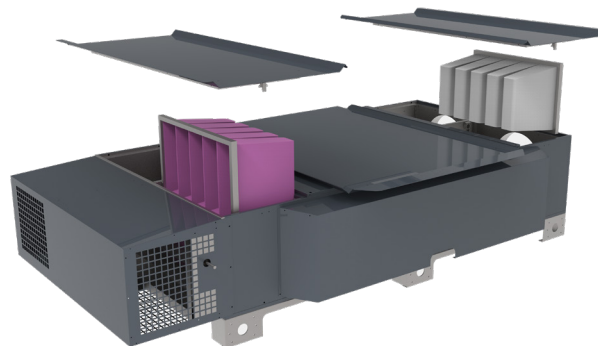

Specification:

Unit size: 08, 10

Supply air: Right (R) / Left (L)

Fan type: none = Composite, ALU = Aluminum

GLOBAL\_LP\_OUT\_XX\_X\_XXX

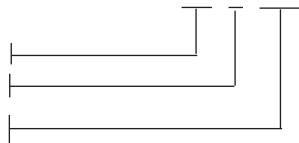

## FILTER REPLACEMENT SET

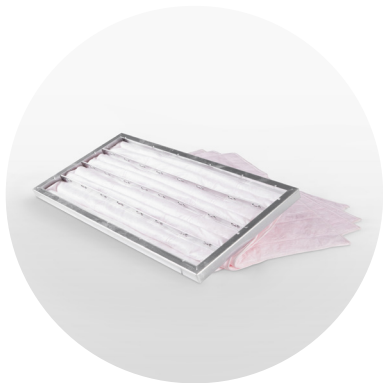

The function of the filter is to keep both the air and the heat exchanger clean. To keep the plate heat exchanger clean, an ePM10 $\geq$ 50% (ISO16890) filter class will suffice. Filterclass of the supply air filter: ePM1 $\geq$ 70% (ISO16890). Filterclass of the extract air filter: ePM10 $\geq$ 50% (ISO16890).

MODEL	Air intake	Extract air	DIMENSIONS
GLOBAL LP OUT 08	ePM1 70%	ePM10 50%	585 x 362 x 300
GLOBAL LP OUT 10	ePM1 70%	ePM10 50%	885 x 362 x 300



## MOTORIZED DAMPER - CT



The CT dampers are used as shut-off dampers. Shut-off dampers are used if the air handling unit is idle during some period or if a water coil is used. The dampers are made of galvanized steel, the blades of the rectangular dampers are made of extruded aluminum. The blades have rubber seals. According to EN 1751, the air tightness of circular dampers is of class 3, the air tightness of rectangular dampers is of class 2.

Specification:

Connection frame [mm]

Duct dimensions [mm]

None = 0

On/off = 1

Spring return = 2

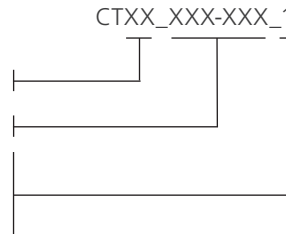

MODEL	Inner dimensions	Outer dimensions	LABEL
GLOBAL LP OUT 08	Ø315	n.v.t.	CT_315
GLOBAL LP OUT 10	360 x 260	440 x 340	CT40_360-260
GLOBAL LP OUT 10	760 x 260	840 x 340	CT40_760-260

## CIRCULAR ADAPTER - IRS

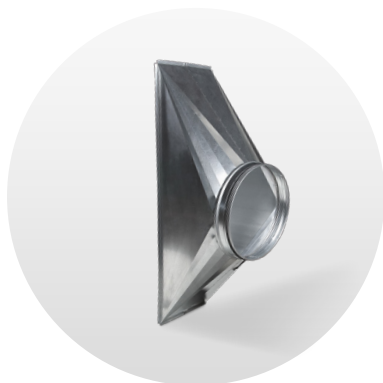

For units (AHU's, external coils, ...) with rectangular connections, non insulated rectangular/circular adapters are available. The adapter is fabricated in galvanized sheet metal. The circular duct connection is fitted with a rubber seal.

Specification:

Frame outer dimensions

Circular size

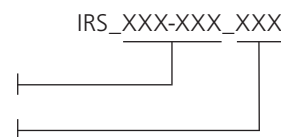

MODEL	DIMENSIONS	DUCT	LABEL
GLOBAL LP OUT 10	400 x 300	Ø315	IRS_400-300_315
GLOBAL LP OUT 10	800 x 300	Ø315	IRS_800-300_315

## FLEXIBLE SLEEVE 20mm - MS20



The flexible sleeves type MS20 prevents the transmission of vibrations and noise along the ventilation ductwork. The sleeve is made of fibreglass and are classified "M0" for fire resistance, "Class B" for air tightness (EN 15727 and EN 1751). The operating range is from -30°C up to +110°C and for pressures up to 2000Pa. The 20mm connection frame is made from 1mm thick galvanized steel.

Specification:

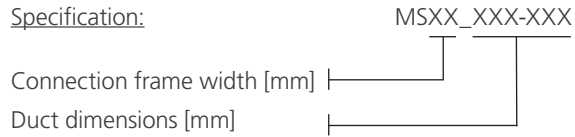

MODEL	INNER DIMENSIONS	OUTER DIMENSIONS	LABEL
GLOBAL LP OUT 08	Ø315	/	MS_315
GLOBAL LP OUT10	400 x 300	440 x 340	MS20_400-300_LP OUT 10
GLOBAL LP OUT 10	800 x 300	840 x 340	MS20_800-300_LP OUT10

## FLEXIBLE SLEEVE 30mm - MS30

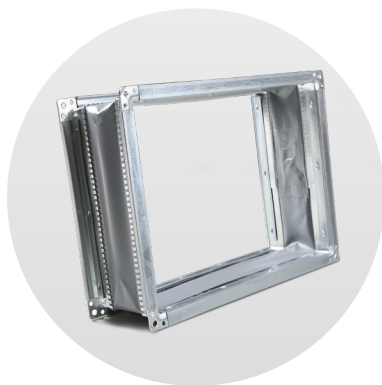

The flexible sleeves type MS30 prevents the transmission of vibrations and noise along the ventilation ductwork. The sleeve is made of fibreglass and are classified "M0" for fire resistance, "Class B" for air tightness (EN 15727 and EN 1751). The operating range is from -30°C up to +110°C and for pressures up to 2000Pa. The 30mm "METU" connection frame is made from 1mm thick galvanized steel.

Specification:

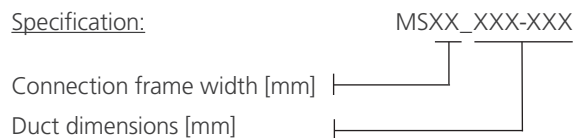

MODEL	INNER DIMENSIONS	OUTER DIMENSIONS	LABEL
GLOBAL LP 10	380 x 280	440 x 340	MS30_380-280_LP 10
GLOBAL LP 10	780 x 280	840 x 340	MS30_780-280_LP 10

## INTERNAL WATER POST HEATING - IBA

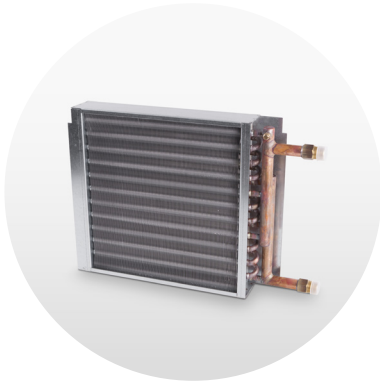

The IBA coil uses hot water for post-heating the supply air. The coil is integrated inside the unit and is located between the plate heat exchanger and the supply air duct connections. The finned-tube heat exchangers consist of copper tubes and aluminum fins with 2,5mm spacing. The male threaded pipe is made of brass. The coils are classified PN16.

Specification:

Coil type & # of rows  
 Coil size

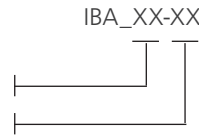

MODEL	VARIANT	Ø	LABEL
GLOBAL LP OUT 08/10	Verwarming	1/2"	IBA_2H_LP 08/10

## BASE FRAME

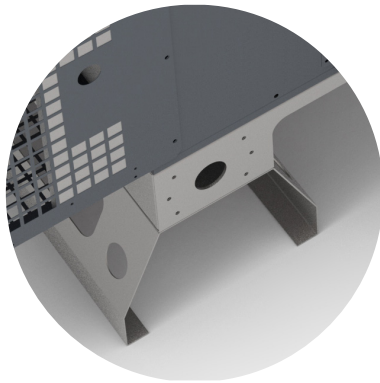

The base frame is a support structure in galvanized steel which will enhance the unit to avoid the contact with snow or water, and which can facilitate the installation of elbow ducts.

MODEL	HEIGHT DIMENSION
GLOBAL LP OUT 08/10	205 mm

## EXTERNAL INSULATED CASING FOR COILS- ECA : FOR INDOOR INTALLATION ONLY

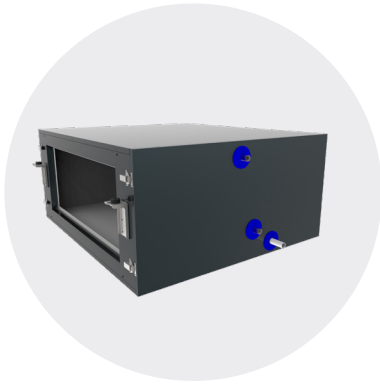

The external insulated casings are fabricated in galvanized steel sheet. the outer sheet is painted in RAL7016. The double-skin panels contain 30mm mineral wool. The casings can be used to integrate external cooling, heating or direct expansion coils (EBA). The standard connection frame is 15mm, other connection frame types are available as an option: 20mm slip clamps, 30mm "METU" frame.

Specification:

Duct size [mm]  
Casing size[mm]

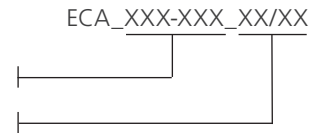

MODEL	DUCT	DIMENSIONS [mm]	LABEL
GLOBAL LP OUT 08	Ø250	400 x 600 x 700	ECA_250_08
GLOBAL LP OUT 10	655 x 250	400 x 900 x 800	ECA_655-250_13

## COILS FOR EXTERNAL INSULATED CASING - EBA

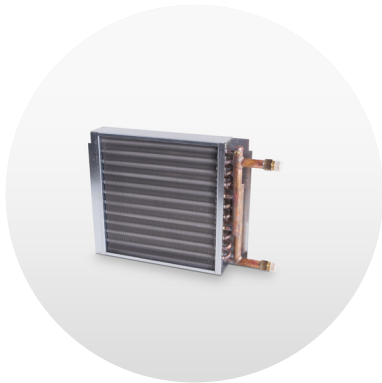

The EBA coil uses hot water for post-heating the supply air. The coil is to be integrated in an insulated casing ECA. The finned-tube heat exchangers consist of copper tubes and aluminum fins with 2,5mm spacing. The male threaded pipe is made of brass. The coils are classified PN16.

Specification:

Function & # of rows  
Coil size

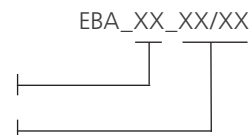

MODEL	DIMENSIONS [mm]	LABEL
GLOBAL LP OUT 08	305 x 130 x 638	EBA_xx_08
GLOBAL LP OUT 10	303 x 130 x 828	EBA_xx_13

## INTERNAL ELECTRICAL PRE- & POST HEATING - KW<sub>IN</sub> & KW<sub>OUT</sub>



The electrical coil is used for post-heating the supply air. The electrical coil is located between the plate heat exchanger and the supply air duct connections. There are two overheating protections, one with manual reset and one with automatic reset. All electrical connections are protected against electrocution.

Specification:

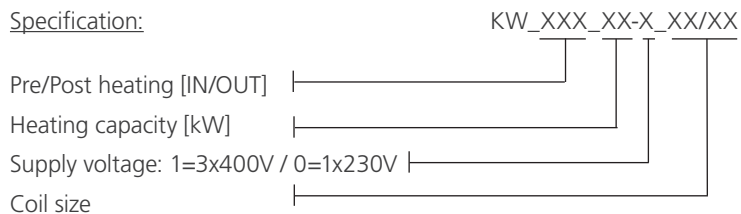

MODEL	CAPACITY KW <sub>OUT</sub>	CAPACITY KW <sub>IN</sub>	POWER SUPPLY	LABEL
GLOBAL LP OUT 08	6.0 kW	6.0 kW	3 x 400 V	KW_IN/OUT_06_1
GLOBAL LP OUT 10	6.0 kW	6.0 kW	3 x 400 V	KW_IN/OUT_06_1





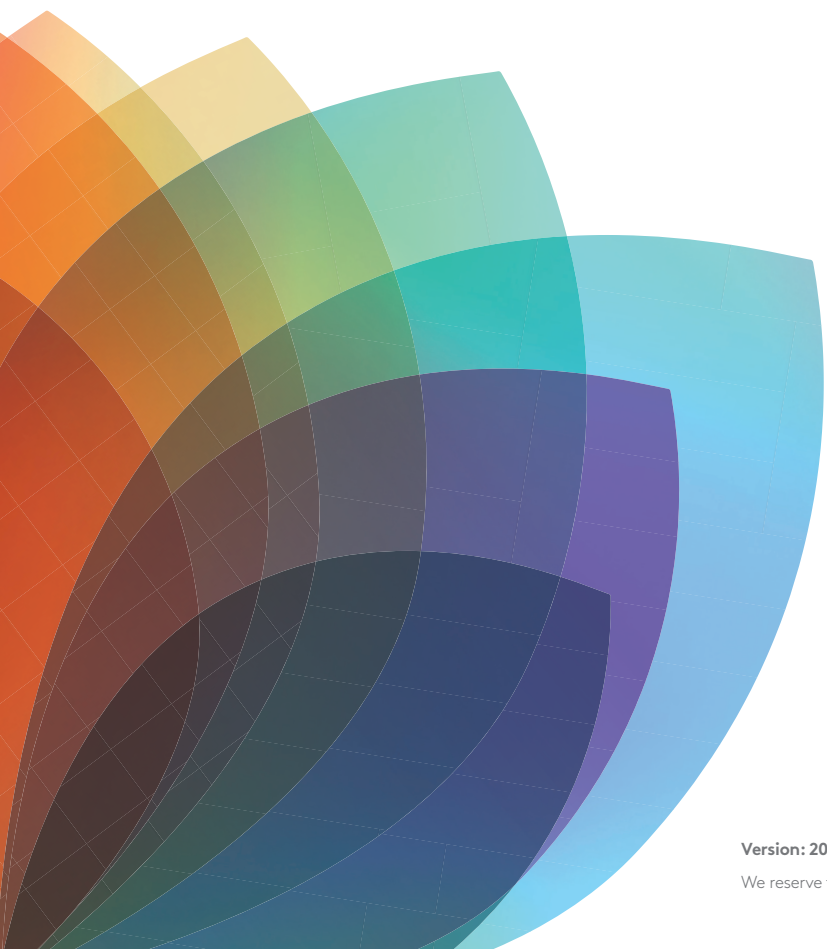

Version: 20210607

We reserve the right for changes.

**Swegon** 